



Offshore Wind Transmission Risk Technical Conference

February 26, 2020

Follow NJBPU
on social media:





Opening Remarks:

Abe Silverman

General Counsel, NJ BPU



Presentation:

Richard Levitan

President, Levitan & Associates

Comparison of OSW Transmission Options

February 26, 2021

Richard Levitan, rl@levitan.com

LEVITAN & ASSOCIATES, INC.
MARKET DESIGN, ECONOMICS AND POWER SYSTEMS

Transmission Study Options Study Goals

- Identify commercial, technical, environmental, and operational (dis)advantages
- Evaluate relative strength of radial export cables and ocean grid designs around 7.5 GW goal
- Assess “power corridor” concept with multiple OSW projects delivering power to a single POI via HVDC
- Review lessons learned from the EU and UK re network grids, centralized approach, project risk

Information Sources

- Initial stakeholder input Nov 2019 – 4 panels
 - Connecting Generation through Shared Transmission Facilities
 - Optimal OSW Transmission Framework to meet NJ's OSW Goals
 - Technical Considerations
 - Cost Responsibility and Business Model Considerations
- Stakeholder meetings July-Aug 2020
 - Contacted 80 representatives from 54 entities
 - Arranged 12 teleconferences (commonality of interests)
- EU OSW transmission studies
 - NYPA: Offshore Wind - EU Perspective
 - DIW ECON: Market Design for Efficient Transmission
 - Navigant: Connecting OSW Farms - A Comparison of Development Models
 - Atlantic Grid: Transmission Policy Lessons from the EU

BOEM Lease Areas

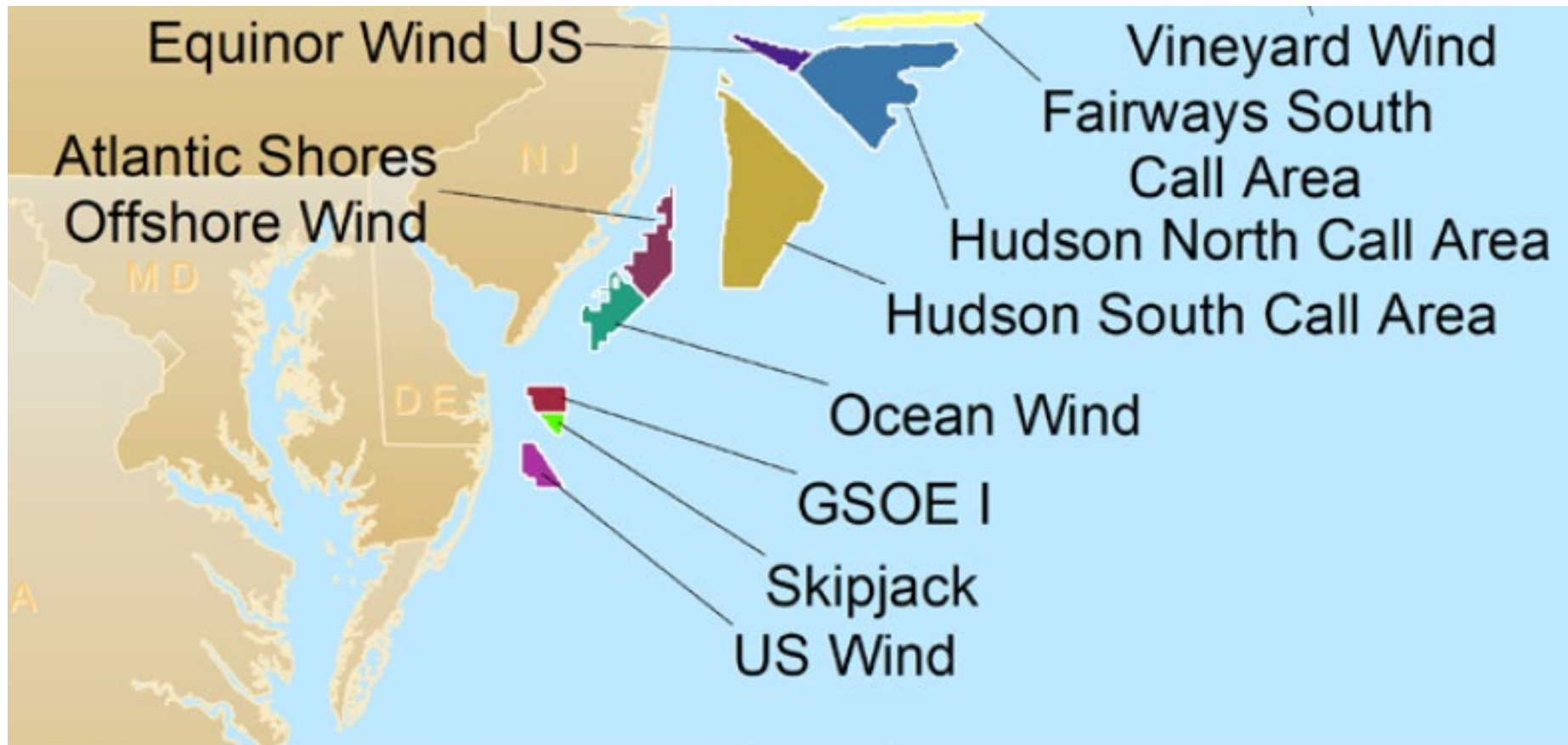

Option 1: Radial Export Cables

➤ Relatively straight-forward option

- Appropriate for single OSW projects
- 1,000-1,200 MW project would use 3 subsea HVAC cables
- Bundles generation and transmission
- Typically connects to 1 POI

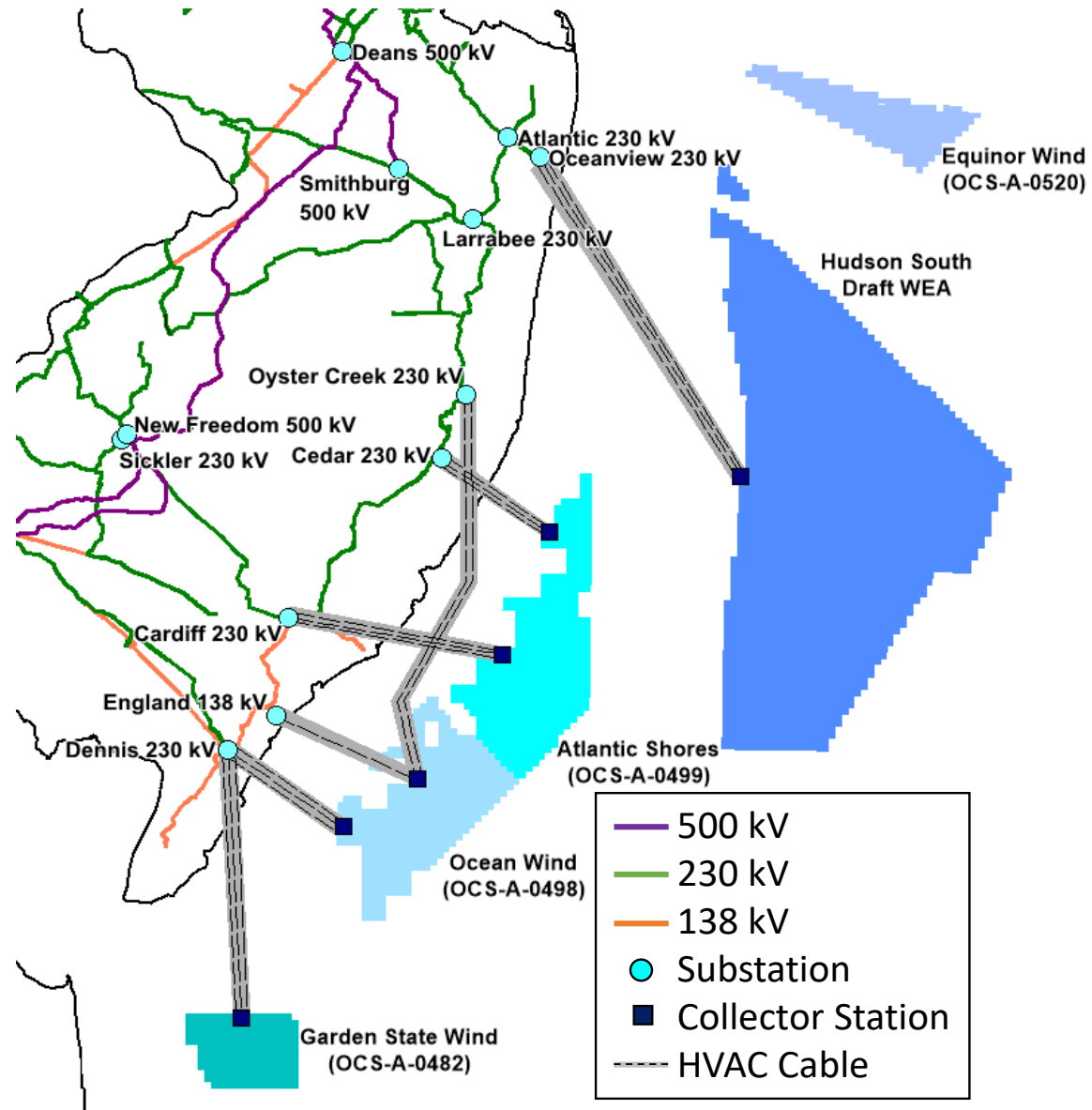

Findings – Radial Export Cables

➤ Bundles generation with transmission

- Traditional approach in NJ, NY, New England, MD

➤ Advantages

- Financeability
- Project development and operating risk borne by developer
- Build what's needed when needed
- Straightforward project cost evaluation and procurement process

➤ Disadvantages

- Higher environmental impacts from multiple shoreline and marine construction efforts
- Must punch through to 500 kV backbone system upon depletion of headroom at coastal POIs

Option 2: Ocean Grid

➤ Connect multiple OSW projects to POIs

- HVDC technology
- Delivery cables to shore plus inter-project cables
- Inter-project reliability concerns
- Optimized power flow
- Larger nameplates limit usefulness

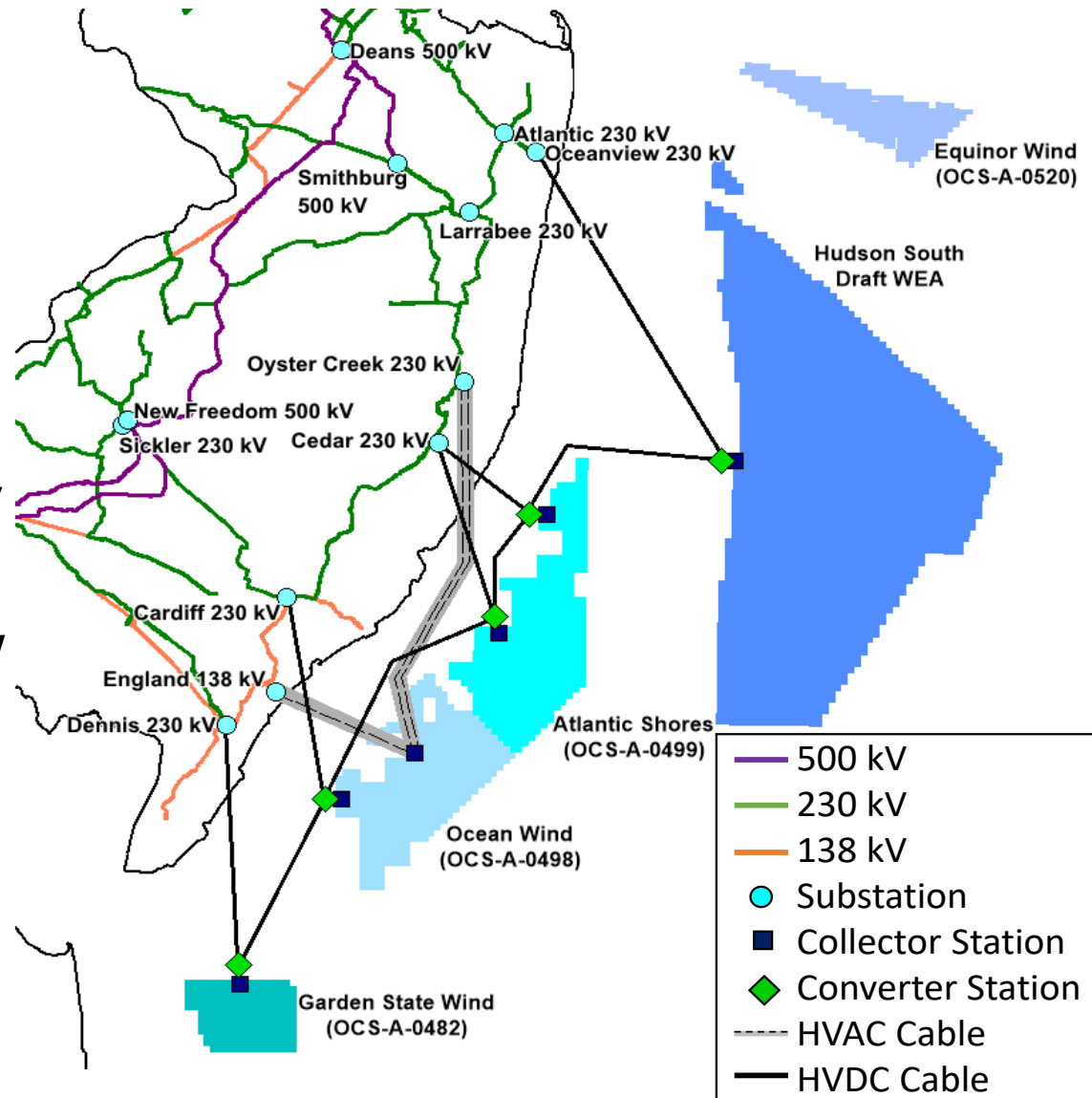

Option 4: Power Corridor

- Extension of hybrid system concept for NJ
 - Multiple HVDC export cables from a single offshore POI in one onshore ROW to 500kV POI
 - Environmental impacts minimized due to HVDC (1 cable) and single construction program
 - No inter-project reliability impacts

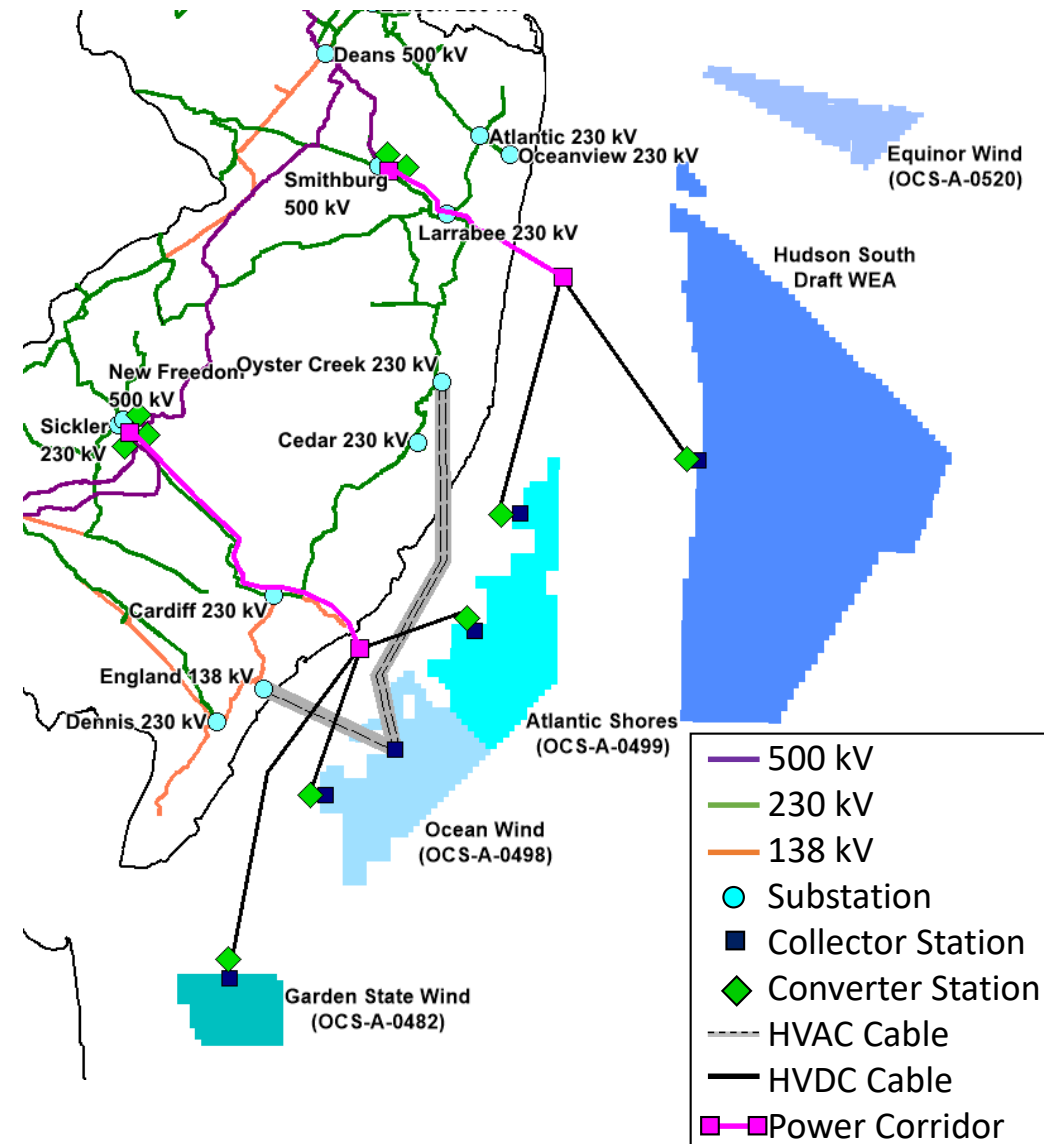

Findings – Ocean Grid and Power Corridor

➤ A coordinated transmission solution

- PJM SAA defines development and regulatory path
- SAA permits cost caps, encourages innovation
- Would be a regulated PJM transmission asset

➤ Advantages

- Environmental benefits of reduced shoreline and marine impacts with single HVDC cables and coordinated construction program
- Leverages headroom at coastal POIs and the 500kV backbone

➤ Disadvantages

- Raises project-on-project risks
- HVDC more expensive for short distances
- Challenge of optionality, i.e., which OSW sites
- Ratepayer onus re fixed non-bypassable charges
- Procurement alignment / timing cycles

Option 3: Hybrid System

- Reflects strong central role of TSOs in nascent EU planning and development
 - TSOs (Germany, Denmark) extend onshore grids offshore
- Connects multiple OSW projects to offshore collector platforms
 - Designed for smaller nameplates, i.e., 250-400 MW
 - Advantages dissipate with larger nameplates, i.e., 1,000+ MW
 - OSW projects use HVAC radial export cables to connect to offshore collector platforms
- Large NJ project nameplates eliminate hybrid system *but may* pave the way for a power corridor

Current State of Technology Play

- OSW nameplates now 1,000 MW+
- HVAC and HVDC subsea cables are reliable
 - NJ lease areas are relatively close to shore
 - HVAC losses increase with distance; HVDC losses do not but converters impose their own losses
 - A coordinated transmission project would likely use HVDC technology
 - HVDC equipment not compatible across vendors
- Technology progress may increase cable voltage & capacities
 - May not be useable in NJ if injections >1200 MW trigger PJM reliability costs
- Construction Issues
 - An ocean grid in one stage represents a formidable undertaking
 - Staging ocean grid construction likely undermines economy
 - Power corridor less complicated / more manageable

EU Lessons Learned

- 22 GW operational BOY 2020 / 70 GW by 2028
 - WTG size, water depth, and distance to shore steadily increased
 - No ocean grids North Sea Power Hub in early planning stages
- UK prefers “developer led” approaches with bundled G&T
 - Developers responsible for interconnection (PJM approach)
 - Radial transmission cables sold off to third parties
- EU TSOs build offshore “network grids”
 - Extensions of onshore grids, different from ocean grids
 - Appropriate for planning / controlling early OSW development
 - Early “wrong turns” (project-on-project risk) very expensive
- Studies have inconsistent conclusions
 - Larger WTGs and projects have led to lower costs
 - Separate G&T requires significant coordination efforts

Business Structure and Finance

- Bundled OSW G&T projects financeable
 - OSW developers have shown strong preference for bundled G&T
- Coordinated transmission must be a regulated asset
 - Merchant transmission model infeasible
- SAA coordinated transmission solution
 - Competition provides incentives for innovation & low cost
 - State / BPU cost assignment of fixed non-bypassable charges
 - Assured cost recovery should lower financing costs absent FERC equity adders
 - Potential achievement of effective cost caps, other risk mitigation measures
- Capital formation predicated on
 - Coordinated transmission solution approved by PJM
 - NJ agrees ratepayers will bear costs
 - PJM administers billing and collections

Environmental & Fisheries Impacts

- NOAA charts for context
- BOEM GIS shows many existing cables, mostly transatlantic telecom
- Cables do not cross sensitive barrier islands
- Habit areas of particular concern are vulnerable to degradation
- Future proofing to avoid multiple construction efforts

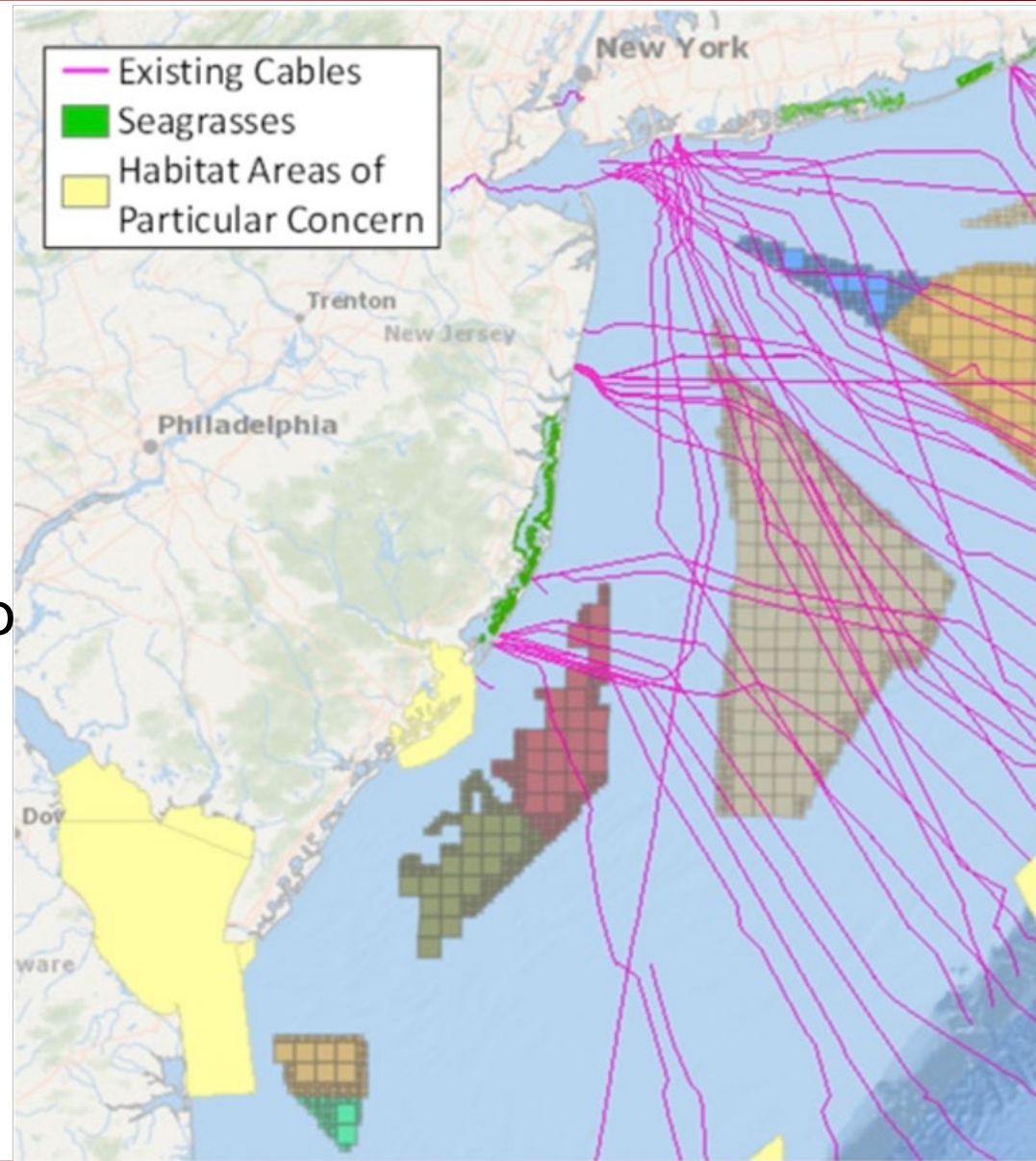

Environmental & Fisheries Impacts

➤ Radial export cables

- More cables have greater potential impacts

➤ Ocean grids

- Single construction effort may reduce permitting risk
- HVDC means fewer shoreline trenches / boreholes
- Additional inter-project cables required

➤ Power corridors

- Single construction effort may reduce permitting risk
- HVDC means fewer shoreline trenches / boreholes
- HVDC cables clustered together in single ROW further minimizes impacts

Long-Term Planning and Flexibility

- Radial export cables provide limited opportunities future-proofing
 - Suitable for individual 1,000-1,200 MW projects
 - Flexible – build what's need when needed
 - May not optimize POI utilization
 - Future projects will likely need to reach the 500kV backbone
- Ocean grids and power corridors provide future-proofing
 - Fosters optimum long-term OSW buildout
 - Power corridors plan for medium-term OSW buildout

Conclusions

- No single correct approach / no easy answers
- Objective function requires tradeoffs, i.e., environmental, cost, ratepayer risk
 - Reliability, in-state economic benefits, and technology choice are not meaningful differentiators
- Environmental efficiency and achievable mitigation strategies may drive long term solutions
 - SAA process should provide innovative, cost-effective options
 - Procurement alignment challenges appear manageable



Presentation:

Joe DeLosa

Bureau Chief of Federal and Regional Policy,
NJ BPU



State Agreement Approach

Joe DeLosa
Board of Public Utilities Staff
February, 2021

Follow NJBP
on social media:





November 18, 2020 Board Order

- New Jersey has a goal of 7,500 MW of offshore wind before 2035
 - › Executive Order 92
- Legislation found potential benefits of shared approach to transmission & authorizes “transmission first approach:
 - › Allows approval of an “open access offshore wind transmission facility ... located either in the Atlantic Ocean or onshore, used to facilitate the collection of offshore wind energy or its delivery to the electric transmission system in this State.” N.J.S.A. 48:3-51. See *also* N.J.S.A. 48:3-87.1(e).
 - › See *also* Energy Master Plan Goal 2.2.1, NJ OSW Strategic Plan, and November, 2019 BPU Offshore Wind technical conference.
- On November 18, the Board formally requested that PJM incorporate New Jersey’s offshore wind goals into PJM’s RTEP.



PJM State Agreement Approach ("SAA") Collaboration

- The SAA set forth in PJM's Operating Agreement provides a vehicle for states to propose a state public policy project to PJM for inclusion in the RTEP.
 - › PJM to post Public Policy Assumptions, pursuant to OA, Schedule 6, §§ 1.5.6(b) and 1.5.8(b).
 - › PJM to convene a project proposal window pursuant to OA, Schedule 6, § 1.5.8(c).
- New Jersey is the first state to take advantage of the PJM SAA process.
- BPU Staff collaborated with PJM on preliminary analyses.
 - › Screening Analysis
 - » Provided information to rank potential injection locations.
 - › Scenario Analysis
 - » Comprehensive evaluation of scenarios created resulting from Phase 1 Screening Analysis.



General Scope

Charts are for illustration only and not intended to suggest specific outcomes or designs.

- At the injection locations recommended, the Order contemplates that the Public Policy Requirement include three inter-related components of an open access offshore wind transmission facility.
- Detailed scoping discussions will occur as competitive window preparations continue, as directed by the Order.

Green:

- Option 1 – Upgrade PJM Transmission system to Shore substations
- Black Outline indicates substations targeted for injections as described below.

Yellow:

- Option 2 – From Upgraded Shore Substations over Beach crossing to New (wet) collector Stations.

Blue:

- Option 3 – Interconnecting collector stations in a “network” or “backbone” to facilitate network delivery of Offshore Wind.

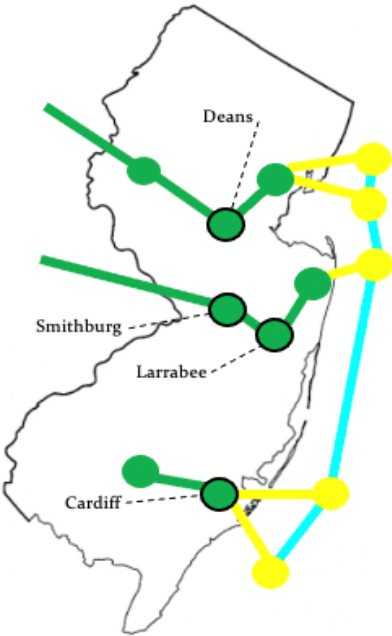



Injection Locations

- Based on PJM and Staff initial analysis, the Board has approved the following injection locations to underlie the SAA window:
 - › 900 MW at the Cardiff 230 kV substation in Southern New Jersey;
 - › 1,200 MW at the Larrabee 230 kV substation in Central New Jersey;
 - › 1,200 MW at the Smithburg 500 kV substation in Central New Jersey; and
 - › 3,100 MW at the Deans 500 kV substation in Northern New Jersey.
- Developers are invited to “propose particularly cost-effective alternatives that may still meet the State’s immediate policy goals, while deferring less cost-effective elements of the transmission expansion until a future transmission solicitation.” (Order at 8)



Onshore Scope – Option 1

- Upgrade the onshore PJM regional transmission system to accommodate the increased power flows from the offshore wind facilities.
- Under this option, offshore wind developers would continue to be responsible for getting the power from the lease areas to the newly constructed or existing on-shore substations.
- Solutions may include coordinated on-shore “power corridors” that would bring electricity to already-existing high-voltage transmission facilities.

Green:

- Option 1 – Upgrade PJM Transmission system to Shore substations
- Black Outline indicates substations targeted for injections as described below.

Yellow:

- Option 2 – From Upgraded Shore Substations over Beach crossing to New (wet) collector Stations.

Blue:

- Option 3 – Interconnecting collector stations in a “network” or “backbone” to facilitate network delivery of Offshore Wind.

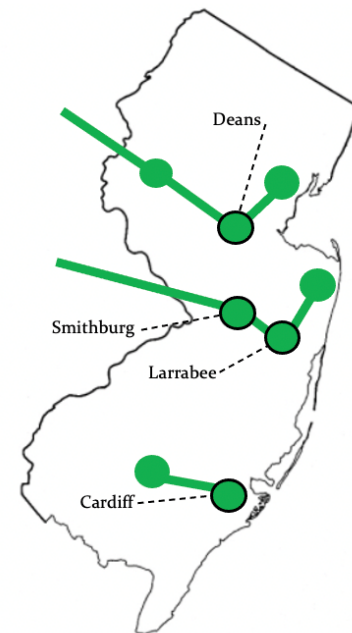



Beach Crossing Scope – Option 2

- This option would involve soliciting bids from transmission developers to permit and construct the beach crossings and connect the (new or existing) on-shore substations to new (wet) offshore collector stations.
- If selected, it would be possible that this option could be selected in addition to Option #1, and offshore wind developers would be responsible for interconnection to the offshore collector platforms.

Green:

- Option 1 – Upgrade PJM Transmission system to Shore substations
- Black Outline indicates substations targeted for injections as described below.

Yellow:

- Option 2 – From Upgraded Shore Substations over Beach crossing to New (wet) collector Stations.

Blue:

- Option 3 – Interconnecting collector stations in a “network” or “backbone” to facilitate network delivery of Offshore Wind.

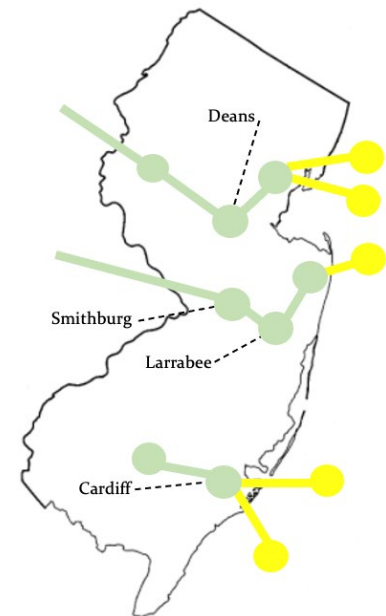



Offshore Backbone Scope – Option 3

- Connect different collector stations, serving various lease areas, in an effort to network the offshore wind lease areas.
- This option could result in network interties between offshore wind collector stations, potentially improving availability, and could also involve bids that include Options #1 or #2.

Green:

- Option 1 – Upgrade PJM Transmission system to Shore substations
- Black Outline indicates substations targeted for injections as described below.

Yellow:

- Option 2 – From Upgraded Shore Substations over Beach crossing to New (wet) collector Stations.

Blue:

- Option 3 – Interconnecting collector stations in a “network” or “backbone” to facilitate network delivery of Offshore Wind.

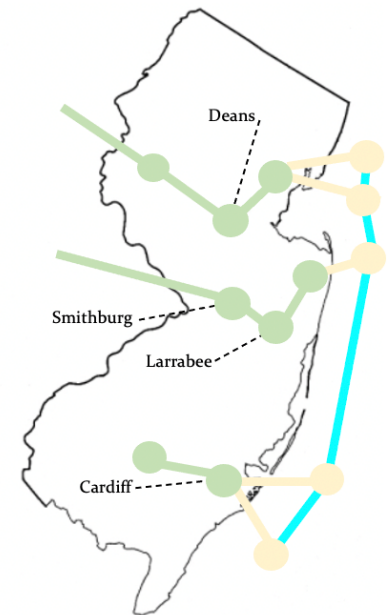



SAA Safeguards

1. November 18 Order is not authorization to proceed with any particular project, but to incorporate Public Policy Requirements into an RTEP planning window.
 - › Any future authorization stemming out of this SAA window would occur consistent with PJM's RTEP approval milestones in 4q 2021.
2. Cost containment provisions in PJM's tariff allow PJM to consider and make recommendations based on voluntarily-submitted binding cost and delivery-date commitments, which will be critical for any evaluation.
3. Allocation of commercial risk between windfarm and transmission developers remains a critical issue; eased by the voluntary submission of binding cost and delivery date commitments from transmission developers.
4. Board is not changing any solicitation requirements for the first or second offshore wind solicitation.



Next Steps

- Order directed Staff to continue collaboration with PJM.
- Transmission Study Agreement – FERC Approved, 174 FERC ¶ 61,090
- Problem Statement for SAA Window.
 - › Environmental Requirements / Constructability
 - › Standardization requirements for future expansion
 - › Cost Cap request
- Transfer of Commercial Risk Discussions – Today!
- Term Sheet.
 - › Cost of future use and expansion
 - › Assignment of capacity rights
 - › Transparent price signal for other states seeking to utilize SAA project
 - › Protection of New Jersey against free-riders



Contact:

- Joe DeLosa
 - › Joseph.DeLosa@bpu.nj.gov

- Hannah Thonet
 - › Hannah.Thonet@bpu.nj.gov



PANEL ONE:

Pre-Commercial Operation Delays, Mis-match of Construction Schedules

Moderator:

➤ Jim Ferris

Bureau Chief of New Technology, NJ BPU

Panelists:

➤ Christian Bjøl

Mid-Atlantic Project Development Director, Ørsted

➤ Doug Copeland

Development Manager, Atlantic Shores

➤ Theodore Paradise

Senior Vice President, Transmission Strategy and
Counsel, Anbaric Development

➤ Sharon Segner

Vice President, LS Power

➤ Lauren Thomas,

Senior Director Transformation and Centralized
Services, PSE&G

Offshore Wind Transmission



February 26, 2021

Ørsted Offshore: Global overview

25+ years of experience and unparalleled track record

The global leader in offshore wind

- > **7.6 GW** installed capacity
- > **2.3 GW** under construction
- > **1,500+** turbines spinning
- > **28** offshore wind farms in operation

The world's first

Vindeby, 1991

5 MW



America's first

Block Island Wind Farm,
2016

30 MW

The world's largest

Hornsea 1, 2020

1.2 GW



Panel One

Pre-commercial operation delays,
mis-match of construction schedules

Christian Bjøl, MidAtlantic Project Development Director

Radial transmission provides the foundation of the offshore wind industry

- Radial transmission is not inherently inferior to other forms of transmission
 - Concentrates risk on the generator, providing ample incentive for transmission and generation to be developed & operational simultaneously
 - The UK established itself as the world leader in offshore wind development, relying on radial transmission to build out about 10 GW of generation



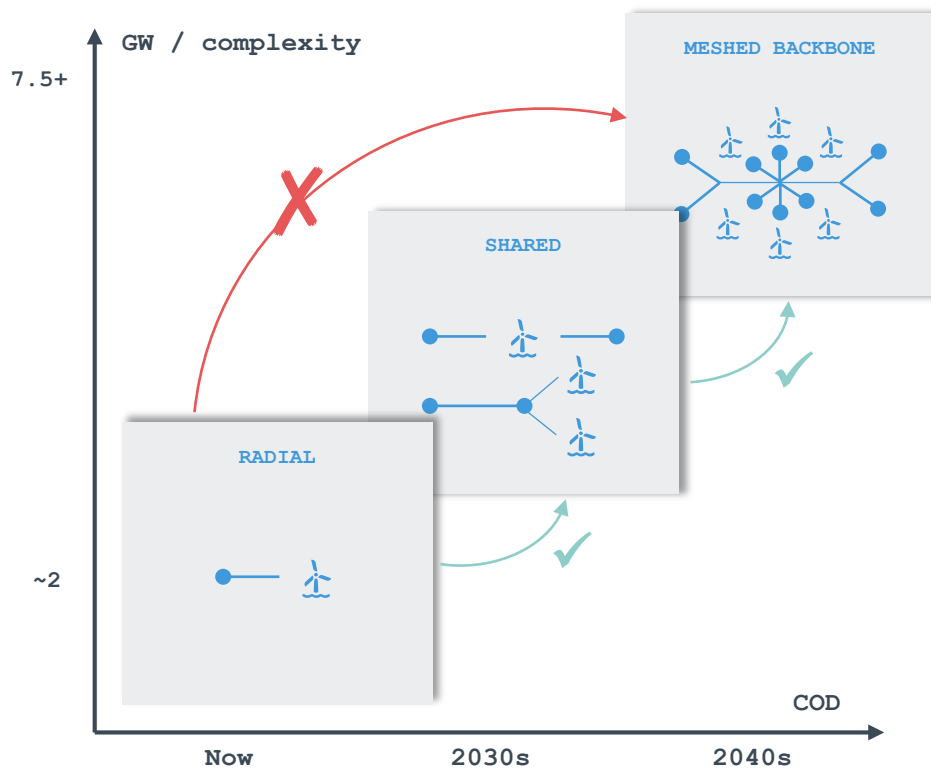

The evolution of offshore wind transmission in New Jersey



To unlock the full potential of offshore wind, a well-planned transmission system needs to accompany generation

What needs to happen:

-  **Radial:** Ensure onshore points of interconnection are robust
-  **Shared:** Pre-commercial & operational risk must be mitigated; begin comprehensive planning with focus on technology readiness like modular solutions and multiterminal systems
-  **Meshed Backbone:** Advanced comprehensive planning; coordination between PJM, NYISO, and ISO-NE and beyond

Pre-commercial risks are real:

German shared transmission system began with delays and damages

Connection delays in the German North Sea

Commission year	Project	Tender and allocation	Development and construction	Thereof: Delays
2010	BorWin1	8	31	7
2015	BorWin2	9	54	14
2015	HelWin1	10	55	22
2015	SylWin1	8	47	2
2015	HelWin2	11	39	no delay
2015	DolWin1	9	53	24
2016	DolWin2	8	54	12
Average		9	48	12

Note: All numbers represent the duration in months of each phase.

Delays

- 7 offshore wind generation projects were delayed an average of 1 year

Costs

- Between 2013 and 2016 alone, German ratepayers had to pay \$1.2B in damages
- Under the German system, the state-owned transmission operator builds the shared offshore system
 - No competition
 - No incentives to finish on time
 - All costs associated with delays and cost overruns passed along directly to ratepayers

Suggested risk mitigation approaches

- Clearly defined liquidated damages
 - Including protections in the event of bankruptcy
- Performance incentives for transmission developers
 - Bonuses for on time or early transmission completion
 - Penalties for delays
- ORECs need to be flexible to protect generators in case of independent transmission delays
- Establishment of technical interconnection standards
 - Not all manufactures of cables and substation components can be connected
- Generators need firm access to transmission rights of way

Thank you



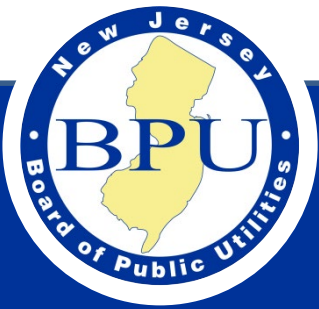

PANEL ONE:

Pre-Commercial Operation Delays, Mis-match of Construction Schedules

Moderator:

➤ Jim Ferris

Bureau Chief of New Technology, NJ BPU

Panelists:

➤ Christian Bjøl

Mid-Atlantic Project Development Director, Ørsted

➤ Doug Copeland

Development Manager, Atlantic Shores

➤ Theodore Paradise

Senior Vice President, Transmission Strategy and
Counsel, Anbaric Development

➤ Sharon Segner

Vice President, LS Power

➤ Lauren Thomas,

Senior Director Transformation and Centralized
Services, PSE&G

Atlantic Shores Offshore Wind

NJ BPU Transmission Conference

Pre-Commercial Operation Delays, Mis-match of Construction Schedules

Atlantic Shores Overview and Lease Area

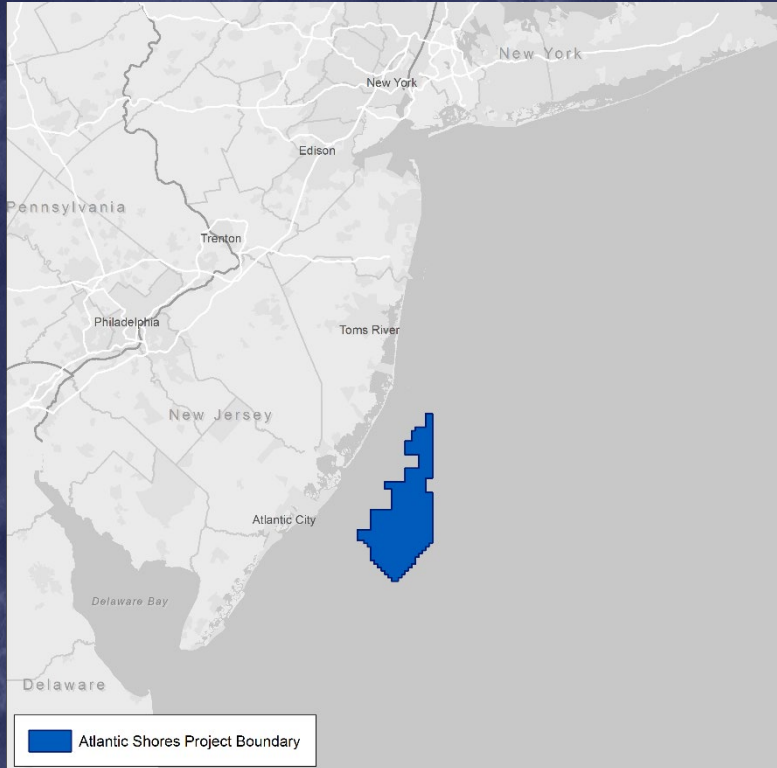

50/50 Joint Venture between Shell Renewables & Energy Solutions and EDF Renewables North America

BOEM Lease Area OCS-A 0499

- Up to 3.0 GW of offshore wind projects
- 183,000 acres
- Approximately 10-20 miles off the coast of New Jersey
- Expected to start delivering power in the mid-2020's

Lease Area Designed to Support a Portfolio of Projects

Atlantic Shores Development Schedule

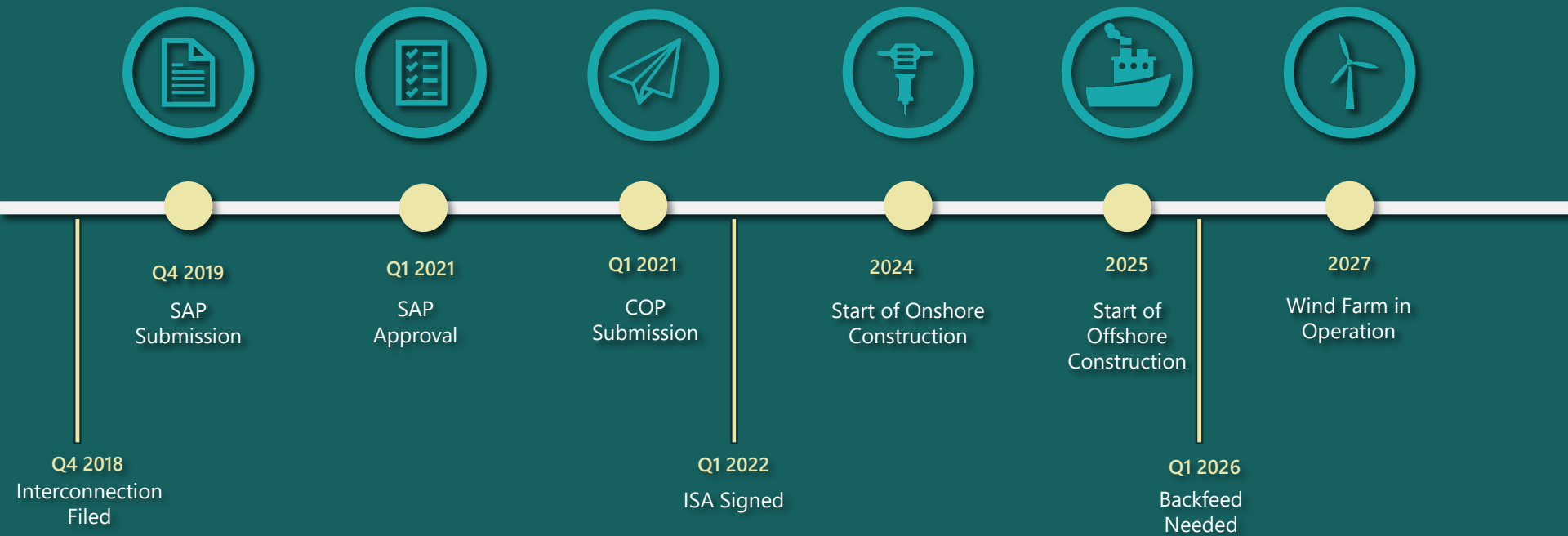

Interconnection Study Landscape & Schedule

The current landscape of queue positions is dynamic and heavily subscribed

Delays impact projects of all types and impact risk across all aspects of the projects:

- Technical Requirements
- Permitting Timelines
- Real Estate Rights
- Delivery Schedule
- Financial Obligations

New queue positions and infrastructure will help projects coming online in 2030 and beyond.

Will the State Agreement Approach help reduce this timeline?

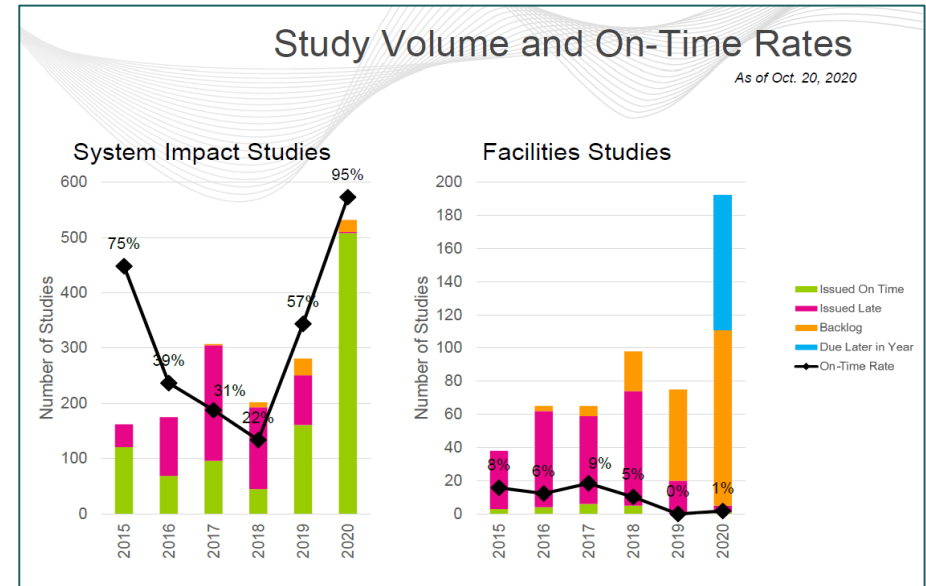

Source: October 2020 PJM Presentation "Interconnection Process Overview"

Next Steps & Questions

BPU Board Order directed Staff to continue collaboration with PJM

Goals

1. More efficient or **cost**-effective transmission solutions vs a non-coordinated transmission planning process;
2. Reduce the risks of **permitting** and construction **delays** resulting from a non-coordinated approach;
3. **Minimize environmental** impacts associated with on-shore and potentially offshore upgrades.

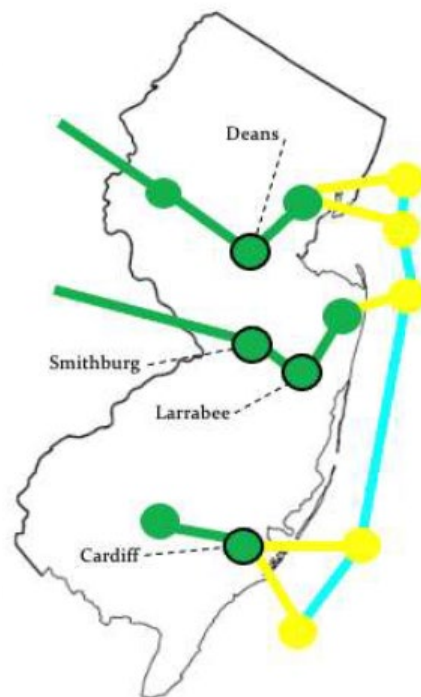

Key Pre-Commercial Questions to Discuss

1. Are these the right locations and right sizes?
2. How can the State Agreement Approach reduce the interconnection timeline?
3. What about the value of current queue positions or any filed before the order is complete?
4. What standardization can be implemented?
5. How does financing community view the risk of unbundled transmission?
6. What, if any, role do the transmission system owners play in Capacity Market payments?
7. How transparent will pricing be?
8. Could onshore transmission capacity be taken by non offshore wind projects?

Thank You

Questions?

Doug Copeland | Development Manager
Doug.Copeland@AtlanticShoresWind.com





PANEL ONE:

Pre-Commercial Operation Delays, Mis-match of Construction Schedules

Moderator:

➤ Jim Ferris

Bureau Chief of New Technology, NJ BPU

Panelists:

➤ Christian Bjøl

Mid-Atlantic Project Development Director, Ørsted

➤ Doug Copeland

Development Manager, Atlantic Shores

➤ Theodore Paradise

Senior Vice President, Transmission Strategy and
Counsel, Anbaric Development

➤ Sharon Segner

Vice President, LS Power

➤ Lauren Thomas,

Senior Director Transformation and Centralized
Services, PSE&G

New Jersey Board of Public Utilities
Transmission for Offshore Wind

Panel One: Pre-Commercial Operational Delays

Who We Are



Helped spearhead the development of two advanced submarine and terrestrial transmission systems: **ON TIME AND ON BUDGET.**



Anbaric Development Partners specializes in the development of large-scale electric transmission systems and storage solutions.

Founded in 2004 by Ed Krapels, Anbaric formed a strategic partnership in 2017 with major pension fund investor, Ontario Teachers' Pension Plan (OTPP). Anbaric is a majority employee-owned US-based company.



Importance of Planned Transmission



Transmission is critical to meeting the states' climate and energy policy goals, as permitting and related upgrades are often the most difficult part of projects. **TWO BASIC WAYS TO DO IT:**

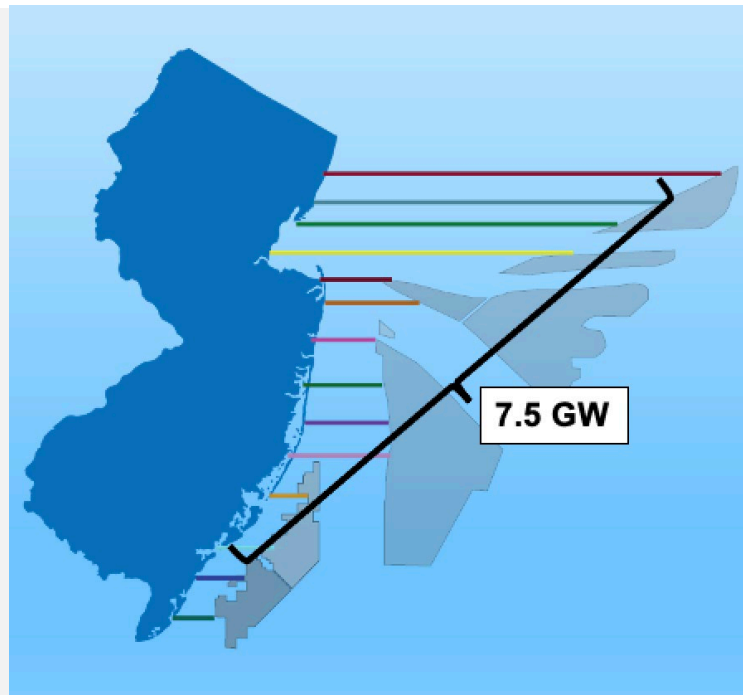

A SINGLE LINE TO EACH WIND FARM

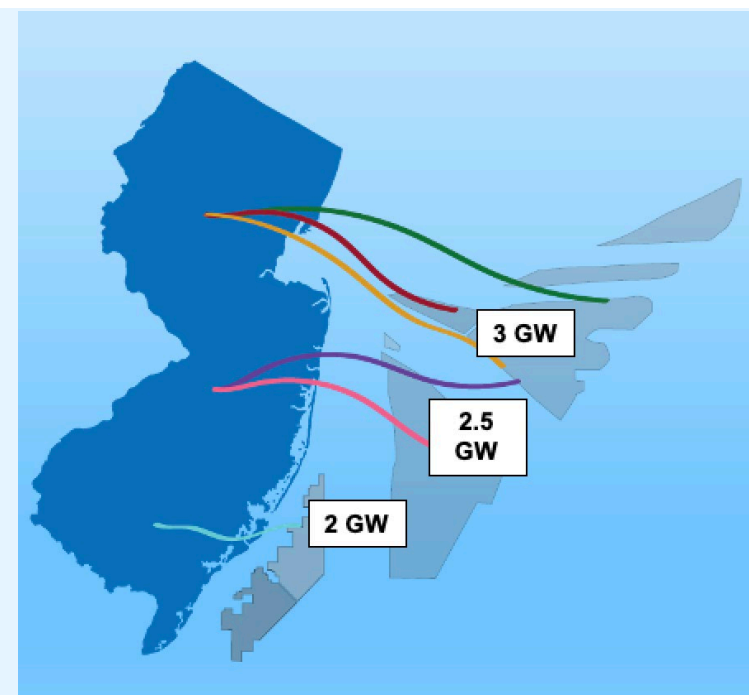

A PLANNED-OUT SYSTEM CONNECTING MULTIPLE WIND FARMS

Improved Reliability & Fuel Security



A planned grid can be designed to be networked from day one allowing grid operators to route power to where it is needed to reduce reliance on fossil plants and fuel delivery systems like natural gas.

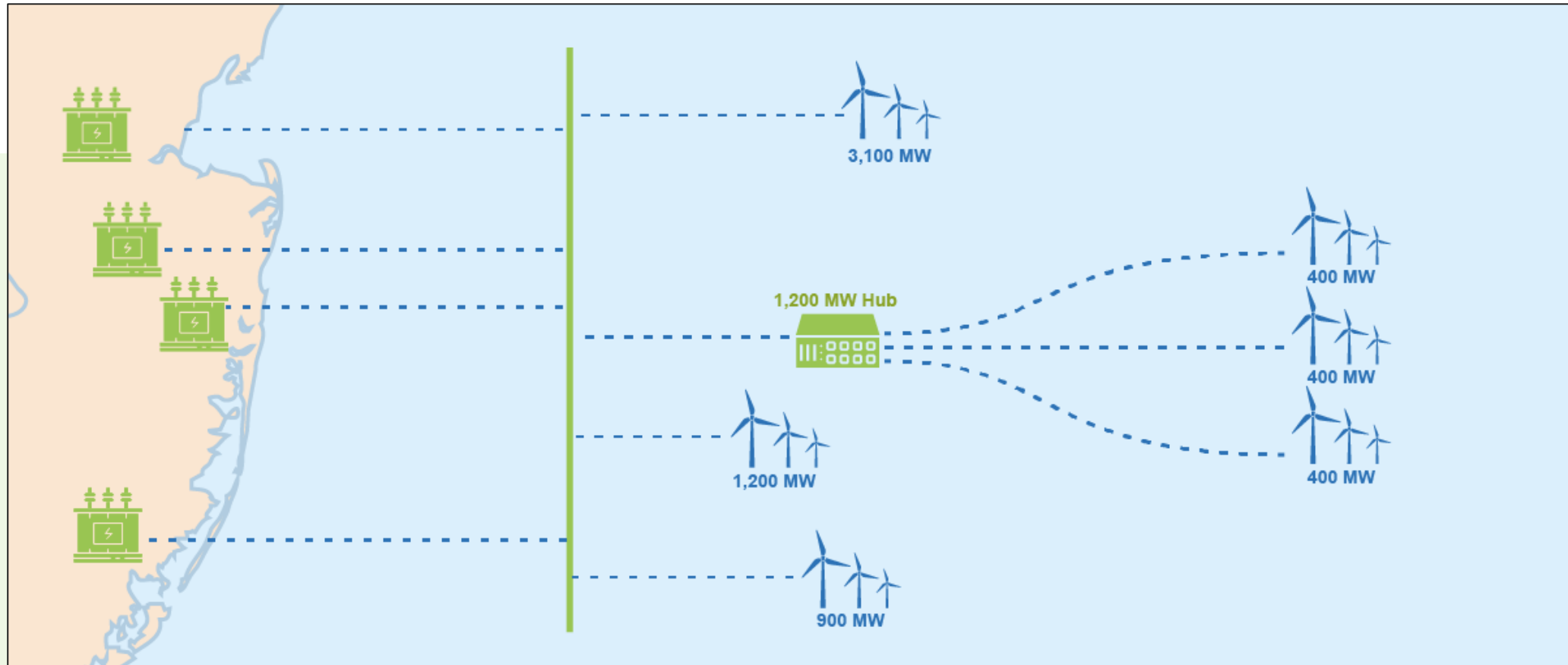

Benefits of Planned Transmission



Recent studies* confirm benefits of planned transmission systems with significant impacts:

Lower costs. Planning and procuring transmission separately from generation increases competition and can reduce transmission costs 20–30%.



Reduced Impact on Fisheries & Marine ecosystems. In NY, a planned transmission approach would reduce cabling by almost 60%, preventing 660 miles of seabed disturbance. In New England, planning transmission for the next 3,600 MW would reduce cabling by about 50%.



Fewer onshore grid upgrades. In New England, a planned transmission approach would result in \$500M in savings. This is critical for cost impacts and avoiding difficult to permit overland projects that can take years to move to construction.



Makes sure states can meet goals. Limited points of interconnection and substations reduces the number of cables that can interconnect to shore. Underutilizing these pathways will result in more expensive set of transmission upgrades in the long run.



Far reduced curtailments vs. radials. With a planned system that delivers to load rather than shortest route, more wind can be used over time. New England study found \$300m/yr in savings from reduced curtailments.



Maximizes competition between wind generators. Planned transmission has led to subsidy-free wind generation auctions in Europe.



- The Brattle Group, *Offshore Transmission in New England: The Benefits of A Better-Planned Grid*
- The Brattle Group, *Offshore Wind Transmission: An Analysis of Options for New York*
- The Brattle Group, *Cost Savings Offered by Competition in Electric Transmission: Experience to Date and the Potential for Additional Customer Value*

Risks of Separate Transmission and Generation Have Been Incorrectly Identified



Genesis of the idea that separate transmission and generation for offshore wind can create a material risk for pre-commercial operational delays arises out of first German build-out of separate offshore transmission system for early offshore wind in 2012.

However, separate transmission and generation did not cause the operational delay

Various factors contributed and were reported at the time, including:

- being under capitalized
- complex project with immature technology
- difficulty securing needed components from a young supply chain

The first attempt at a transmission build out of transmission for offshore wind did not demonstrate that separate transmission and generation creates operational delay risk, but that there were significant challenges to building significant transmission at the time.

Separate Transmission for Offshore Wind is a Success



Significant separate transmission has been built in European waters since 2012 and operational delays from the separate transmission has not been an issue. In fact, separate transmission has been embraced to effectuate timely connection and scaling of significant offshore wind.



A European Perspective From Hard-Earned Experience

Policymakers need to recognize that the ocean, if it's to serve as a dominant energy source, **must have its own planned, independent, offshore grid**. In other words, governments should think beyond early procurements and insist on infrastructure that can support long-term growth.

WILFRIED BREUER
FORMER MANAGING DIRECTOR OF TENNET

With Impressive Economic Results



In Europe, this approach to planned open access offshore transmission has helped lead to zero-subsidy bids by wind generators, with The Netherlands and Germany leading the way.

NETHERLANDS

2 0 1 7

NETHERLANDS' FIRST ZERO-SUBSIDY OFFSHORE AUCTION

- First zero-subsidy OSW farm to be built in Netherlands by 2022.

GERMANY

2 0 1 7

ZERO-SUBSIDY BIDS AWARDED IN GERMAN AUCTION

- OWP West (240 MW) and Borkum Riffgrund West 2 (240 MW).
- He Dreiht OSW farm (900 MW).

Countries That Started With Radials Are Moving To Planned Systems



- The United Kingdom is a best cast for radial transmission development for offshore wind given its extensive coastline. But even here, Ofgem has determined that the nation will move to a planned “meshed” grid approach going forward.

We do not consider that individual radial offshore transmission links for this amount of offshore generation are likely to be economical, sensible or acceptable for consumers and local communities.*



Making a positive difference
for energy consumers

- Working with government and industry, Ofgem will assess how a more “coordinated” offshore transmission system could reduce financial and environmental costs, the regulator said.

ForwardWorkProgramme
consultation 2020-2022

* <https://www.reutersevents.com/renewables/wind-energy-update/windy-december-lifts-orsted-2019-profit-uk-develop-new-offshore-grid-networks>

Shared Network Benefits are Significant and Even a Few Years Delay Can Impact



Significant savings and reduction in number of electrical assets are a key driver for the UK, but delay even to 2030 can reduce benefits by half.

Source: National Grid ESO February 2, 2021 presentation to New England states

<https://newenglandenergyvision.files.wordpress.com/2021/02/bstojkovska-02-02-2021-draft.pptx>

Offshore Network Coordination – Key Messages



£6 billion (18%) potential savings by **2050** if integration starts from 2025



The number of assets could be reduced by **50%** creating significant environmental & social benefits



Benefits are reduced the later integration begins – by half if integration starts in 2030.



Flexibility is needed to deliver projects in train without putting their delivery and the 2030 offshore wind target at risk



Support for commercial deployment is needed to deliver all of the required technology



Additional onshore infrastructure is required to connect wind, however integration can minimise the overall increase in infrastructure

Planned Transmission Reduces Risk



Transmission is the most difficult aspect of offshore wind due to permitting. Permitting on land can take seven plus years and derail projects. Planned transmission mitigates this by:

- ALLOWING FOR ALL PERMITTING TO BEGIN TOGETHER EVEN IF SYSTEM IS BUILT IN PARTS OVER YEARS.
- ALLOWING REGULATORS TO SEE **ALL IMPACTS TOGETHER**.
- **ELIMINATING THE COMMUNITY FATIGUE** OF FOLLOW-UP PERMITTING FOR EACH NEW PROJECT THAT COMES TO SHORE.
- **OPENING ROADS ONCE** TO ADVANCE-INSTALL EMPTY TRANSMISSION CONDUIT FOR FUTURE CABLE INSTALLATION, REDUCING COSTS OF LATER PROJECTS AND AVOIDING LOCAL OPPOSITION.

Competitive Caps & Supporting Information



Competitive transmission can bring with it significant consumer benefits including:

- cost caps
- capped return on equity
- longer depreciation

While other significant benefits – discussed earlier – follow from a planned, shared transmission system

Even a very similar project can present very different risk and benefit profiles. To understand the risk associated with any given transmission project, the BPU should require the submission of reporting on work done to mitigate risk, and why a given project may be more desirable.

This should include, for example, information regarding:

- Feasibility of a given design and route
- Advanced work, completed or underway, that mitigates risk

Planned Transmission Addresses Operational Risks as Well



As discussed, a planned, shared transmission system can deliver significant reliability, cost and ecological benefits to consumers while allows a transition away from the fossil fueled generation contributing to climate change.

These very design elements – that provide such significant reliability benefits – keep offshore wind generators much more insulated from operational losses, and protect consumers from having to buy more expensive replacement power. That’s because even the loss of a large cable does not take wind farms offline. Instead, wind farms stay on-line utilizing other transmission paths to shore.

This certainty of delivery will also be important to the State of New Jersey and the system operator as traditional generation is retired and offshore wind is more greatly relied on.

Planned Networks Are For Today

States developing offshore wind system can make use of planned transmission today. Using planned transmission immediately is the best way to reduce risk, maximize the cost saving and environmental benefits, and optimize the use of the existing on-shore grid.

- **NO NEW TECHNOLOGY STANDARDS** ARE NEEDED
- **CURRENT & LIKELY FUTURE BOEM** WIND GENERATOR LEASE AREAS ARE KNOWN

www.Anbaric.com

www.twitter.com/anbaric

www.twitter.com/t_j_paradise

THANK YOU





PANEL ONE:

Pre-Commercial Operation Delays, Mis-match of Construction Schedules

Moderator:

➤ Jim Ferris

Bureau Chief of New Technology, NJ BPU

Panelists:

➤ Christian Bjøl

Mid-Atlantic Project Development Director, Ørsted

➤ Doug Copeland

Development Manager, Atlantic Shores

➤ Theodore Paradise

Senior Vice President, Transmission Strategy and
Counsel, Anbaric Development

➤ Sharon Segner

Vice President, LS Power

➤ Lauren Thomas,

Senior Director Transformation and Centralized
Services, PSE&G

Public Service Enterprise Group

Company Information

- Public Service Enterprise Group Inc. (PSEG) is a diversified energy company headquartered in Newark, N.J
- PSEG has approximately 13,000 employees
- Public Service Electric and Gas Co. (PSE&G) is New Jersey's largest provider of electric and natural gas service – serving 2.3 million electric customers and 1.9 million gas customers
 - PSE&G service territory runs from the northern part of the state near NYC to the southwest part of the state near Philadelphia

PSE&G Transmission Experience

- As an infrastructure company, PSE&G has an outstanding record of consistently delivering challenging projects within schedule and on budget
- PSE&G maintains over 350 miles of underground transmission
- Since 2010, PSE&G's Projects and Construction organization has increased the mileage of the underground fleet by nearly 30%

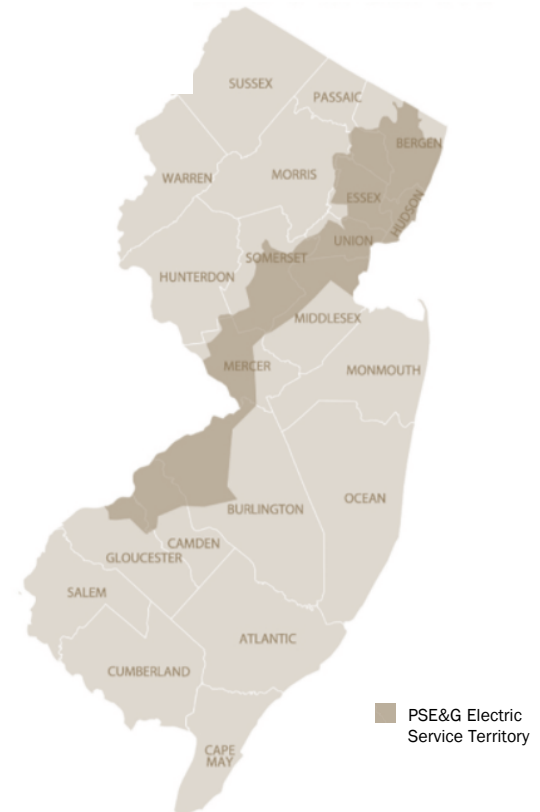



PANEL ONE:

Pre-Commercial Operation Delays, Mis-match of Construction Schedules

Moderator:

➤ Jim Ferris

Bureau Chief of New Technology, NJ BPU

Panelists:

➤ Christian Bjøl

Mid-Atlantic Project Development Director, Ørsted

➤ Doug Copeland

Development Manager, Atlantic Shores

➤ Theodore Paradise

Senior Vice President, Transmission Strategy and
Counsel, Anbaric Development

➤ Sharon Segner

Vice President, LS Power

➤ Lauren Thomas,

Senior Director Transformation and Centralized
Services, PSE&G



INTERMISSION



PANEL TWO:

Curtailment Risk

Moderator:

- Dr. Kira Lawrence
Eagleton Science Fellow, NJ BPU

Panelists:

- Timothy Frost
Vice President, Electric Transmission, Con Edison
- Michael Kormos
Senior Vice President, Transmission and Compliance, Exelon
- Howard Kosel
Partner, Anbaric
- Lorenz Mueller
Head of Regulatory Affairs, 50Hertz Transmission GmbH

Con Edison Transmission

Tim Frost

**NJ BPU Offshore Wind
Technical Conference on Risk**

February 26, 2021

NJ OFFSHORE WIND TRANSMISSION

New Jersey goals

New Jersey is pursuing open access offshore wind transmission to reach its OSW goal.

Northeast offshore lease area map

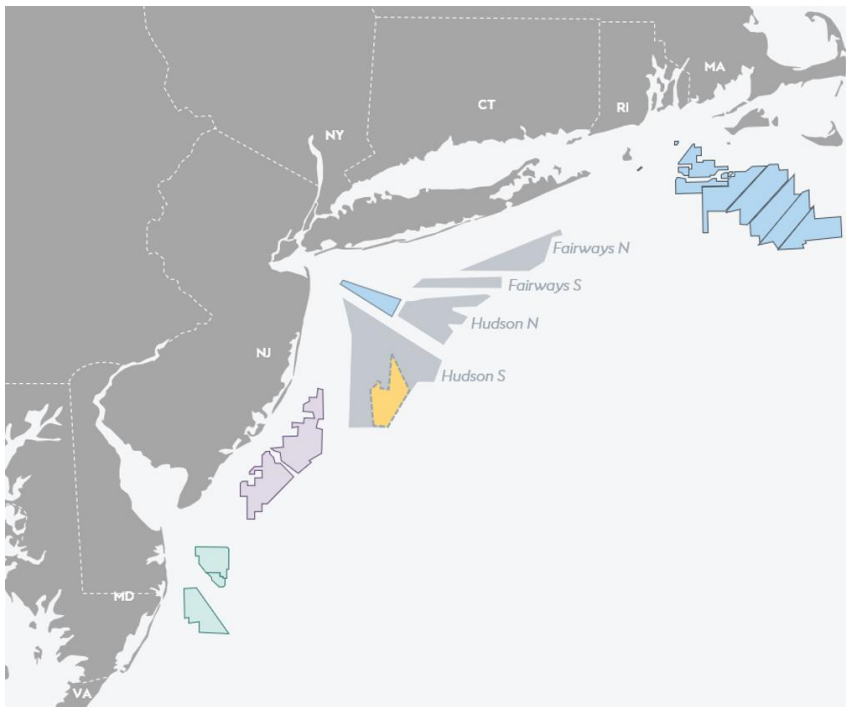

Opportunity

- Demand/supply is tight for the region
 - Supply: ~23 GW – existing lease potential
 - Demand: ~29 GW – state goals
- NJ offshore wind goal: 7,500 MW
 - Award - 1,100 MW awarded to Ocean Wind
 - Current solicitation: 2,400 MW
 - Need for goal: 4,000 MW
- Remaining opportunities
 - Atlantic Shores: 2.5 GW
 - Ocean Winds: ~1 GW
 - US Wind: ~1 GW
 - New York Bight leaseholds
 - Auctioned in 2021
 - Expected to be 3+ GWs
 - Potential bids from South MA leaseholds

NJ OFFSHORE WIND TRANSMISSION

NJ proposed RFP solutions

NJ BPU directed PJM to seek potential transmission solutions for three inter-related components to position NJ to achieve its offshore wind goals.

RFP Elements

- Green:**
- Option 1 – Upgrade PJM Transmission system to Shore substations
 - Black Outline indicates substations targeted for injections as described below.
- Yellow:**
- Option 2 – From Upgraded Shore Substations over Beach crossing to New (wet) collector Stations.
- Blue:**
- Option 3 – Interconnecting collector stations in a “network” or “backbone” to facilitate network delivery of Offshore Wind.

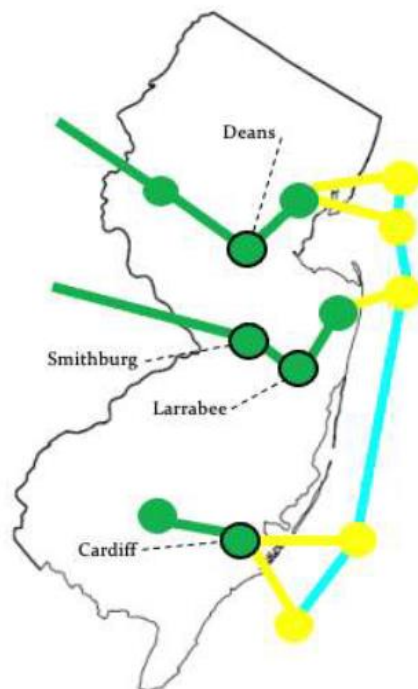

Comments

- Green: PJM Grid to On-Shore Substations
 - Recognition of dramatic change in flows across the state and need not to strand or curtail power at the shore station
- Yellow: On-Shore Substations to Offshore Collector Platforms
 - Recognition that existing power infrastructure is not at the shoreline
 - CET focus on difficulty of siting landfall infrastructure and leveraging established assets
- Blue: Offshore Transmission network
 - Provides reliability goals to ensure the future is not dependent on radial lines and risks of curtailments

NJ OFFSHORE WIND TRANSMISSION

Onshore reliability

Offshore wind will redirect most power flows in New Jersey and create curtailment potential

Sensitive shore areas

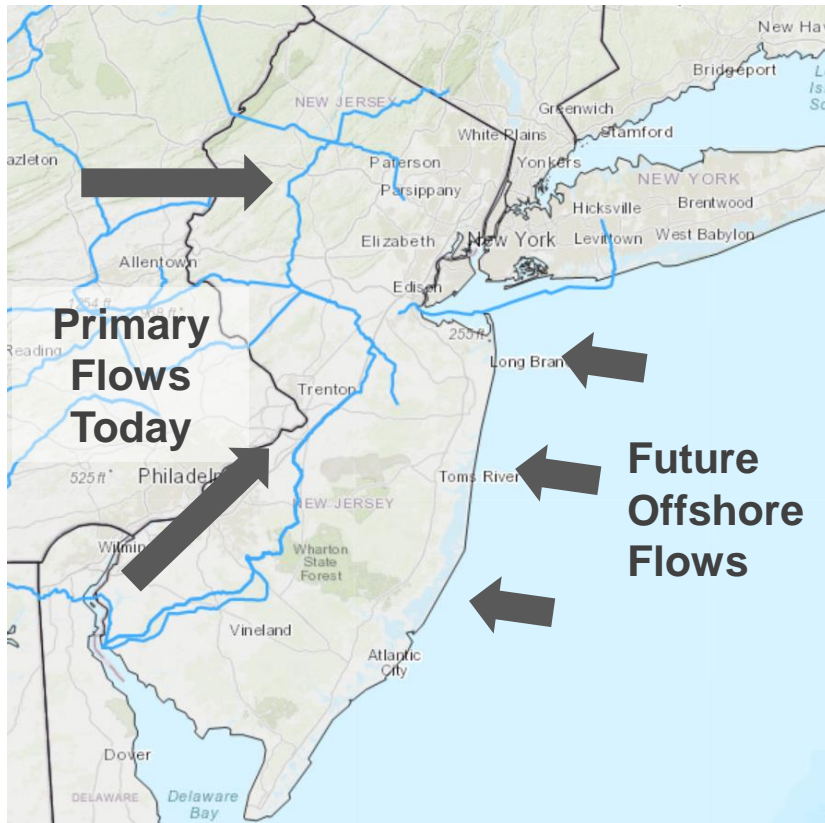

Source: S&P

Description

- NJ's 7,500 MW offshore wind target represents almost half of the state's existing installed capacity
- Major lines are not near shore, and extensions are required to avoid curtailments
- Simultaneously, heating and transportation electrification is expected to bring significant demand changes
- Grid operators must maintain reliability amid these dynamic conditions

NJ OFFSHORE WIND TRANSMISSION

Offshore networks and reliability

CET views the offshore grid as an opportunity for enhancing reliability and capturing scale to afford infrastructure at landfall.

New Jersey and offshore leaseholds

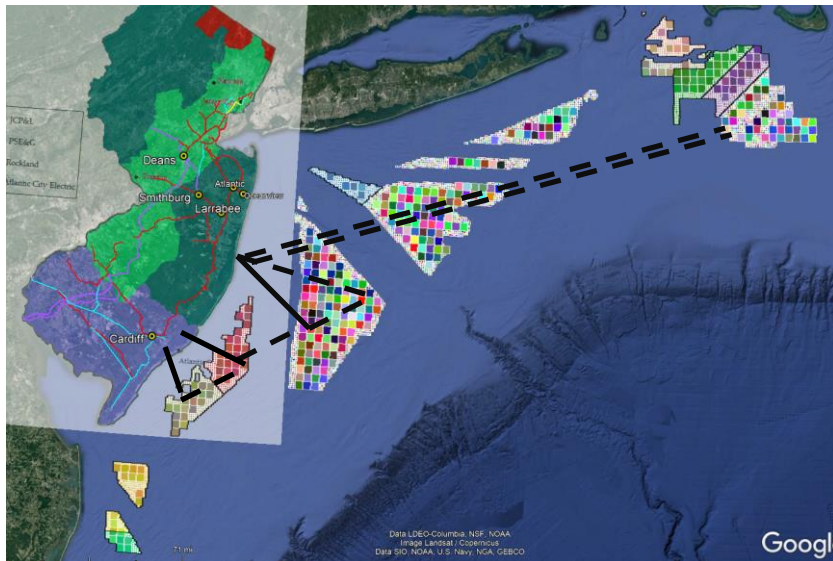

CET experience/insights

- CET has spent significant time and resources understanding the complexities of landing cables in crowded, sensitive shore areas and integrating offshore wind into the electric grid
- Reliability of an offshore grid involving secondary paths (loops) rather than depending on radials transmission to shore
- Lines connecting wind farms create scope for infrastructure investment and create reliability and resilience
- A framework where delivery of offshore wind is accommodated at more than one bus bar would be a significant advance

NJ OFFSHORE WIND TRANSMISSION Con Edison Transmission

CET is a subsidiary of Consolidated Edison, Inc. focused on expanding high-voltage electric transmission to facilitate a clean energy future.

- CET experience
 - CET is the offshore wind partner of Bay State Wind's 880 MW Sunrise Wind project, located east of Montauk, NY
 - Significant evaluation of infrastructure for landfall in shore communities
- CET offshore vision
 - Reliability of an offshore grid is about reliability loops versus radials
 - Enable NJ to achieve its OSW goals by attracting the NY Bight supply
- CET experienced in developing partnerships
 - Important for the complexity of challenge



Photo: Sunrise Wind

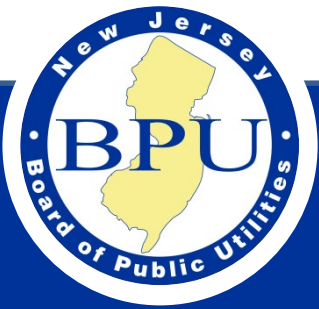

PANEL TWO:

Curtailment Risk

Moderator:

- Dr. Kira Lawrence
Eagleton Science Fellow, NJ BPU

Panelists:

- Timothy Frost
Vice President, Electric Transmission, Con Edison
- Michael Kormos
Senior Vice President, Transmission and Compliance, Exelon
- Howard Kosel
Partner, Anbaric
- Lorenz Mueller
Head of Regulatory Affairs, 50Hertz Transmission GmbH

A photograph of an offshore wind farm with several white wind turbines on yellow foundations in the ocean under a blue sky with light clouds.

NJ BPU Technical Conference Curtailment Risk

Friday, February 26, 2021

ANBARIC

the future of electricity

Planned Transmission is critical to ensuring that New Jersey achieves its OSW targets while minimizing Curtailment Risk and Ratepayer Impact

1

CURTAILMENT AND CONGESTION COSTS
Impact Ratepayers & Underutilize Resources

2

CURTAILMENT PLANNING AND MITIGATION
should be a consideration from the start of planning

3

BEYOND THE BENEFITS OF REDUCED CURTAILMENT,
NJ can increase Resiliency with a Networked Ocean Grid

Methodology: Integrating 7,500 MW of Offshore Wind

Anbaric commissioned transmission planning studies to determine the most cost-effective way to inject 9,000 MW of offshore wind into New York State. Anbaric has engaged DNVGL to conduct a similar study for New Jersey's 7,500 MW goal. This is currently underway and once completed it will be available for review.

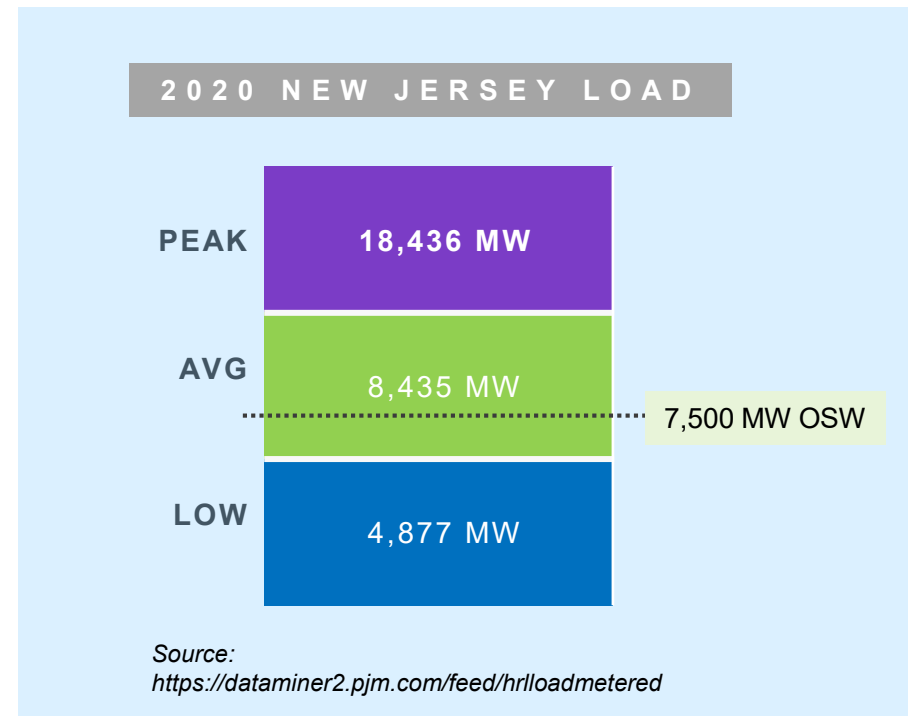

Curtailment and Congestion Costs



OSW Integration Study Methodology Utilized in New York but applicable to New Jersey

- ➔ **Select the most robust Points of Interconnection** to achieve New York goal of 9,000 MW by 2035
- ➔ **Performed interconnection study** using NYISO's Minimum Interconnection Standard (MIS) for grid reliability (load flow, thermal, voltage, etc)
- ➔ **Additionally performed production cost and economic dispatch model** to simulate security constrained unit commitment in grid operation. Hitachi ABB GridView ® software was utilized.
- ➔ **Where curtailments were observed** solutions above and beyond MIS were modeled and tested
- ➔ **Cost Benefit Analysis** of solutions was then conducted
- ➔ **An identical methodology** would be applied to New Jersey's 7,500 MW Goal

Smart Transmission Planning Maximizes Ratepayers' Investment New York Example adding Elective Transmission Upgrades to Mitigate Congestion and Curtailments

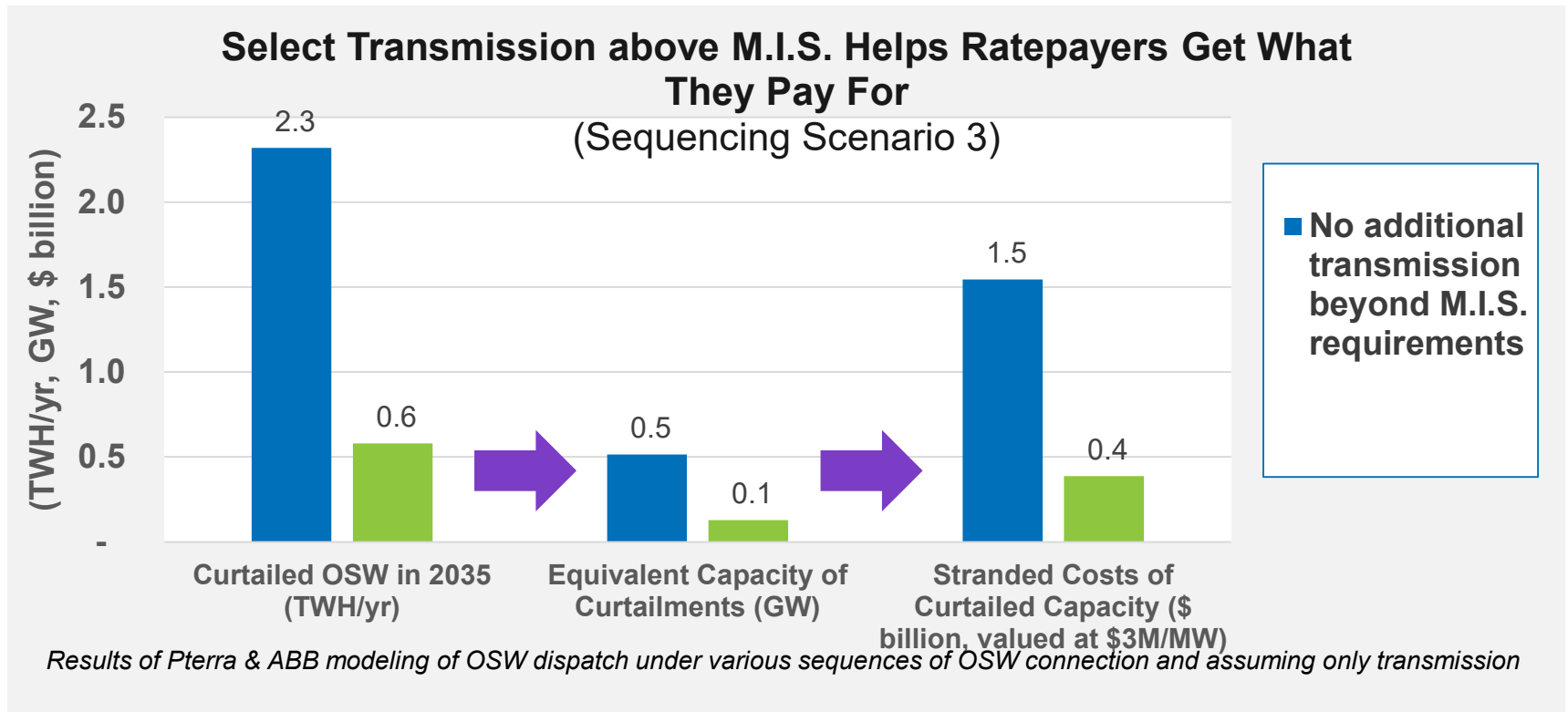

Over \$70M Potential Annual Savings For Ratepayers With Planned Transmission

LONG ISLAND DEMAND \$ CONGESTION PAYMENTS	
2035 Modeled Year	Million \$ per year
Using only MIS	195.2
Using 2 Curtailment Relief Transmission Upgrades	122.1
Savings	73.1

Managing Curtailment Risks

- ✓ **Production Cost & Economic Dispatch modeling** is equally as important as Interconnection Modeling
 - ✓ produces “day ahead curtailments” and should be modified to reflect “real time curtailments”
 - ✓ which as studied in a Brattle Group market simulation study could significantly underestimate curtailments
- ✓ **Local Transmission Grid Upgrade solutions** can be modeled and tested to mitigate potential curtailments
- ✓ **Modify Cost Benefit Analysis criteria for local transmission upgrades** needed to reduce renewable energy curtailments to offset the additional renewable energy that would otherwise have been needed to achieve the States goals.
- ✓ **Path for Local Transmission Upgrades** similar to PJM’s RTEP Market Efficiency process
- ✓ **Apply the same methodology** for Local Transmission Upgrades to Offshore Grid Upgrades

New Jersey Offshore Grid Role in Curtailment Mitigation

In the Atlantic Wind Connection (AWC) outlined and example of how to integrate 6,000 MW of offshore wind into PJM, reinforcing the onshore grid between NJ, DE, MD, and VA much of which is applicable to New Jersey today

The design is characterized as a Backbone Offshore Grid

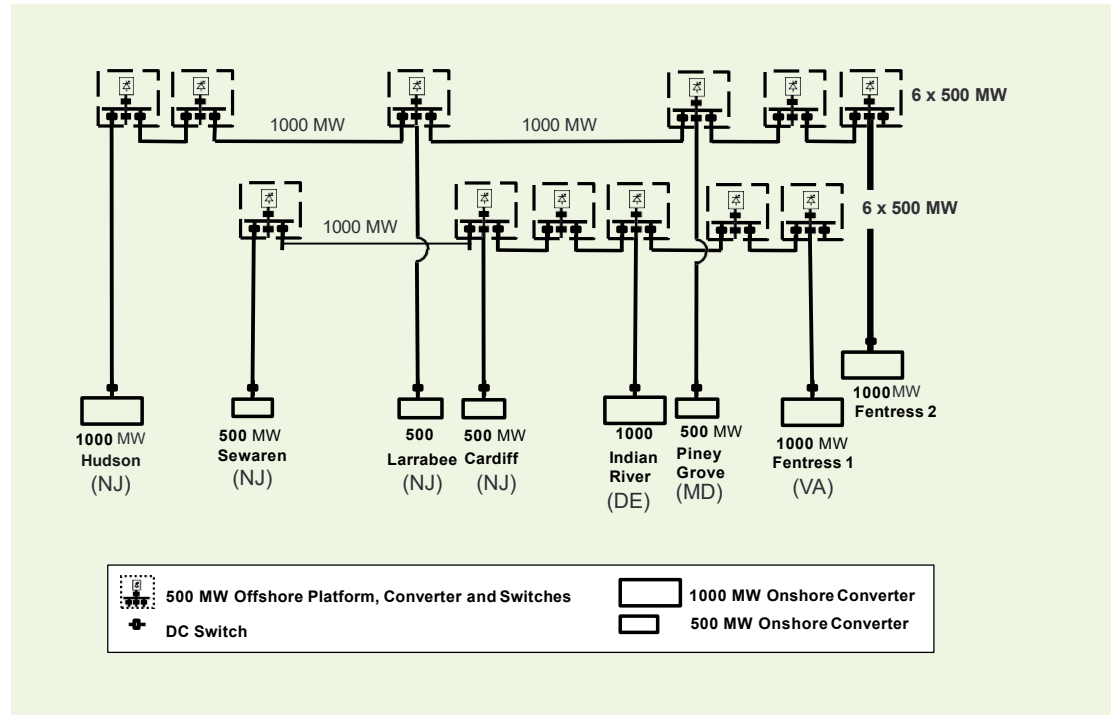

OSW Networked Grid Benefits

From the Brattle Study “An Assessment of the Public Policy, Reliability, Congestion Relief, and Economic Benefits of the Atlantic Wind Connection Project December 21, 2010” summarizes the benefits comparing of the AWC Project to radially interconnected individual wind farms with regard to congestion relief amongst many other benefits.

Similar Congestion Relief Benefits as these shown below could reasonably be expected for a New Jersey offshore grid:

- **Congestion relief benefits:**
 - NPV of reduced production costs measured in PROMOD — \$350 Million
 - NPV of additional production cost savings in real-time— \$310 Million

Added Resiliency & Reduced Curtailments with Planned Transmission

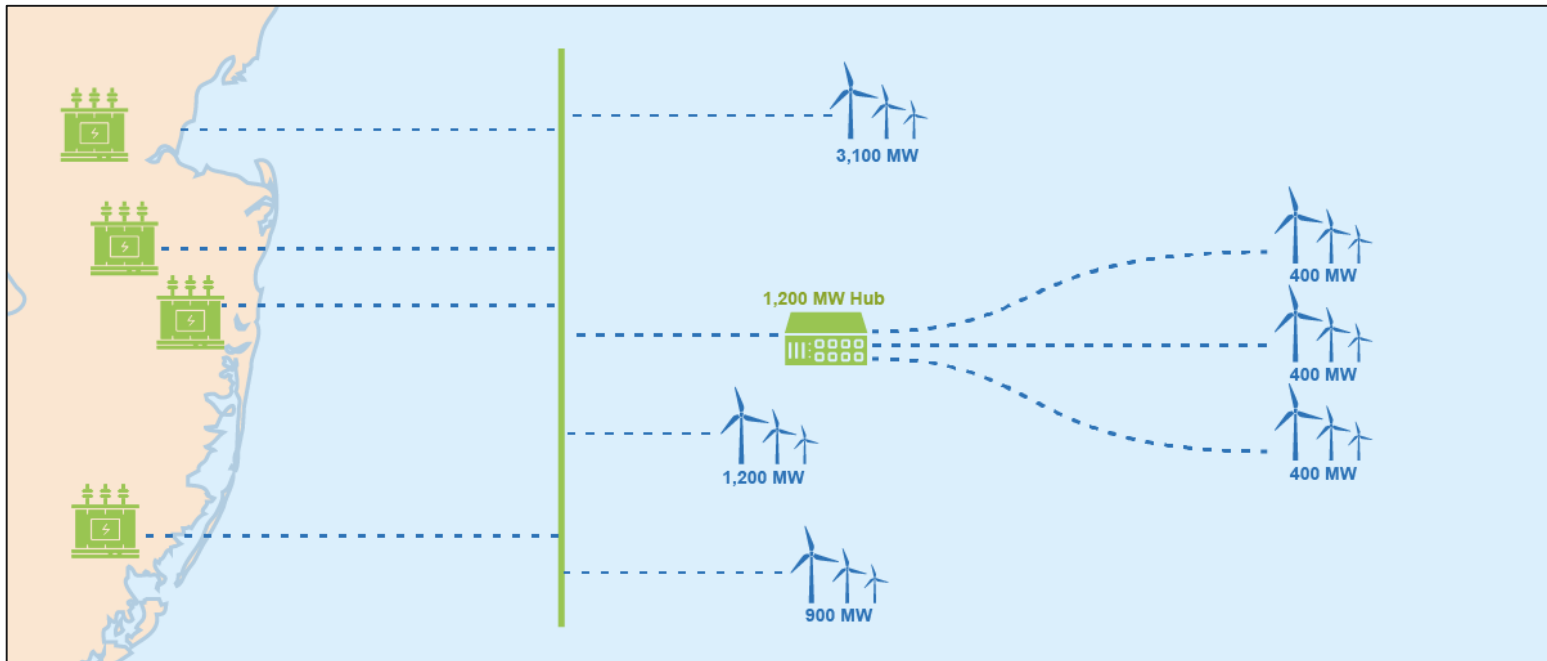

The final design should be driven by the overall long-term economics of the system, reliability, contingency events, technology, location of points of interconnection, licensing & permitting, environmental impact, location of new WEA's.

PLANNED TRANSMISSION:

Crucial Infrastructure to achieve New Jersey Goals and Optimize Ratepayers' Investment in Offshore Wind



CURTAILMENT RISK MITIGATION

- **Point of Interconnections pre-screened and designated as OSW injection points as the NJBPU has done**
- **Production Cost Modeling essential to understanding curtailments**
 - Historically recognize that “day ahead” Production modeling could result in drastically underestimating curtailments
 - The reductions in annual real-time renewable are 2 to 40 times higher than those in the day-ahead market¹
 - Modify Production Modeling methodology to reflect “real time curtailments” as seen in day to day grid operation
- **Model and test local transmission upgrade solutions for highest Cost Benefit Ratio**
 - Modify Cost Benefit Analysis criteria for local transmission upgrades to include the addition of supplemental renewable energy that would otherwise be needed offset to offset curtailments to achieve the States goals.
 - PJM’s Market Efficiency RTEP process manages solutions to congestion
- **Model and test Backbone Offshore Wind Grid configuration and benefit of being able to move power where it is most needed to mitigate curtailments**

Appendix

PRESENTATION SOURCES AND REFERENCES

- Pterra Report R101-20 Rev 5 Transmission Study for Offshore Wind Generation in New York
- Brattle Group
 - [An Assessment of the Public Policy, Reliability, Congestion Relief, and Economic Benefits of the Atlantic Wind Connection Project](#) *December 21, 2010*
 - [The Value of Diversifying Uncertain Renewable Generation through the Transmission System](#) *September 2020*
 - [Offshore Wind Transmission: An Analysis Of New England And New York Offshore Wind Integration](#) *October 23, 2020*
 - [Initial Report on the New York Power Grid Study](#)



PANEL TWO:

Curtailment Risk

Moderator:

- Dr. Kira Lawrence
Eagleton Science Fellow, NJ BPU

Panelists:

- Timothy Frost
Vice President, Electric Transmission, Con Edison
- Michael Kormos
Senior Vice President, Transmission and Compliance, Exelon
- Howard Kosel
Partner, Anbaric
- Lorenz Mueller
Head of Regulatory Affairs, 50Hertz Transmission GmbH

Renewable Energy and Impact on the System in Germany

2021-02-25



Elia Group Two Transmission System Operators in the heart of Europe



- Among the top 5 leading transmission system operators in Europe
- 18,990 km of high-voltage connections that supply power to more than 30 million end-users
- Reliability level of 99.999 percent
- Elia Group is a frontrunner in the transition of the energy sector

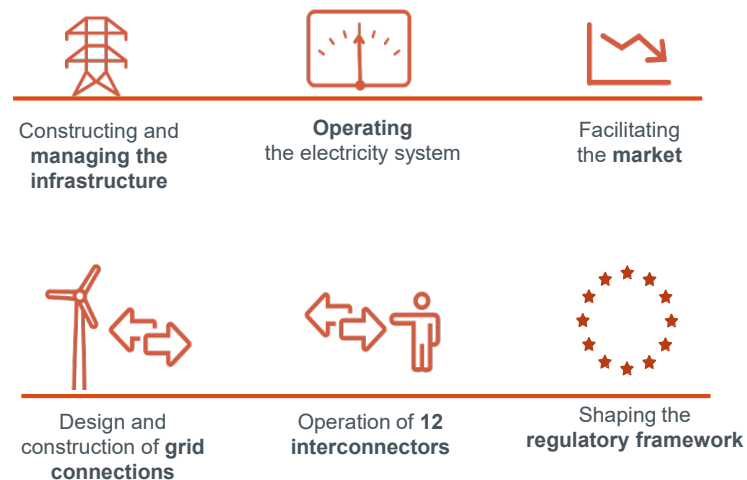

Elia Group – major player in offshore infrastructure (1): projects Germany



No	Project	Technology/Capacity	Commissioning
1	Kontek	600 MW DC (LCC)	1996
2	Baltic 1	48 MW – 150 kV AC	2011
3	Baltic 2	288 MW – 150kV AC	2015
4	Wikinger	350 MW – 220 kV AC	2017
5	Arkona	385 MW – 220 kV AC	2018
6	KF CGS	400 MW DC (VSC B2B) 150 kV AC (Intercon.cable)	2020
7	Arcadis Ost 1	250 MW – 220 kV AC	2022/2023
8	Baltic Eagle	500 MW – 220 kV AC	2023/2024
9	Hansa Power Bridge	≈ 700 MW – 300 kV DC	2025/2026

Development of renewable energy sources (RES) in Germany

Area proportional to the installed capacities

● PV ● Wind ● Biomass

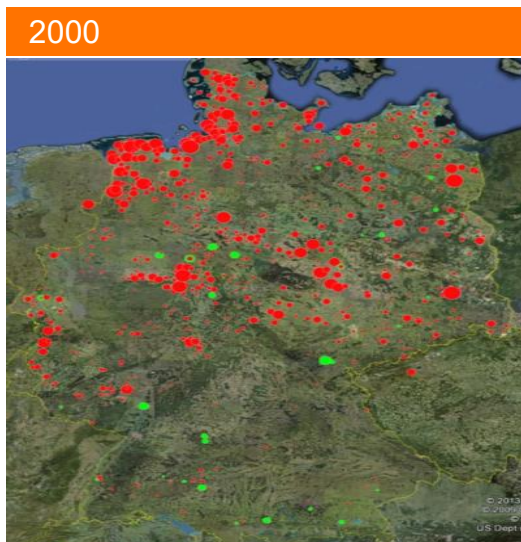

- ~ 30,000 plants
- 1,665* MW inst. wind in Germany

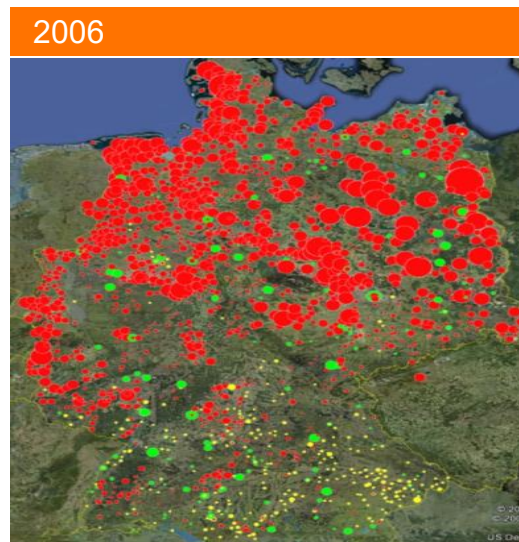

- ~ 221,000 plants
- 2,233* MW ins. wind in Germany

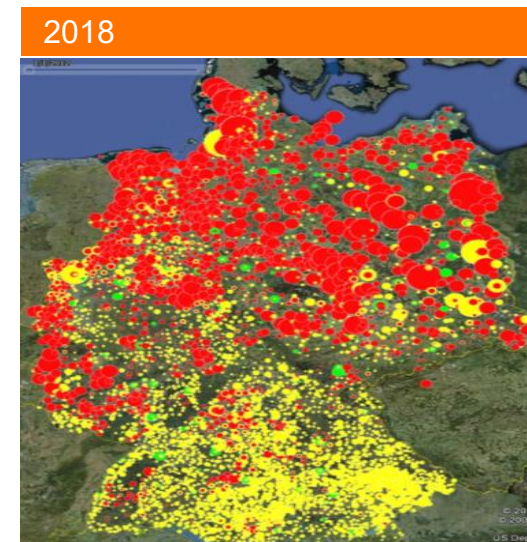

- > 1,600,000 plants
- 49,628* MW inst. wind in Germany
- 41,687* MW PV

Political targets and support schemes have led to a massive growth of RES.

Source: 4 German TSOs, Google Earth; *preliminary data

Europe's and Germany's ambitious political targets

	EU goals	German goals
CO₂ emissions reduction ¹	2030: 55%*	2020: 40% 2030: 55% 2050: 80-95%
RE Share in power consumption	2030: 32%	2025: 40-45% 2030: 65% 2050: 80%
Efficiency²	2030: 32,5%	2050: 50%

2019: 35%

DE 2019:
42.6%

50Hertz
2019: 60%

2017:
5.5%

**50Hertz target:
100% by 2032 !**



* European Green Deal target

1 Compared to 1990 levels

2 Compared to 2008 levels

Generation of renewable energies mainly in the North; consumption mainly in the South and West – challenge to the grid

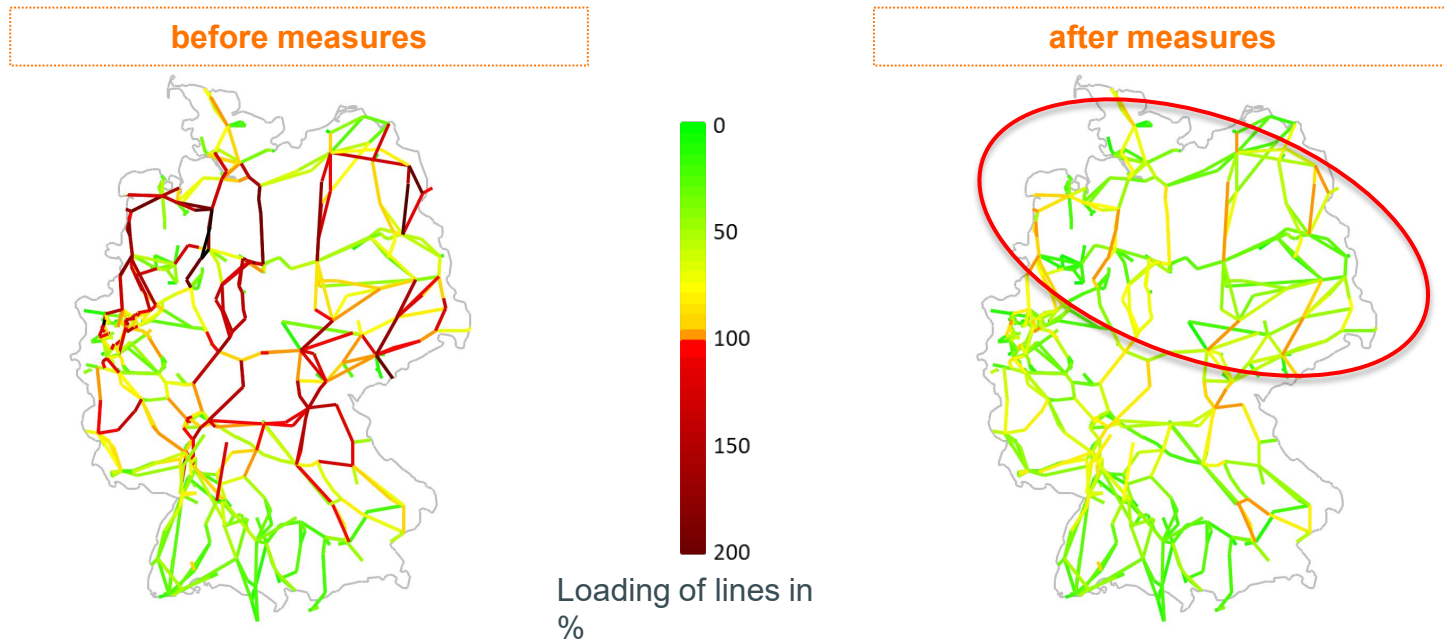

Source: Needs assessment 2020, Dimensioning grid usage case, Time horizon (t+1) - winter 2020/21

Transfer capacity of the grid can be increased through different measures – partly contributed by RES

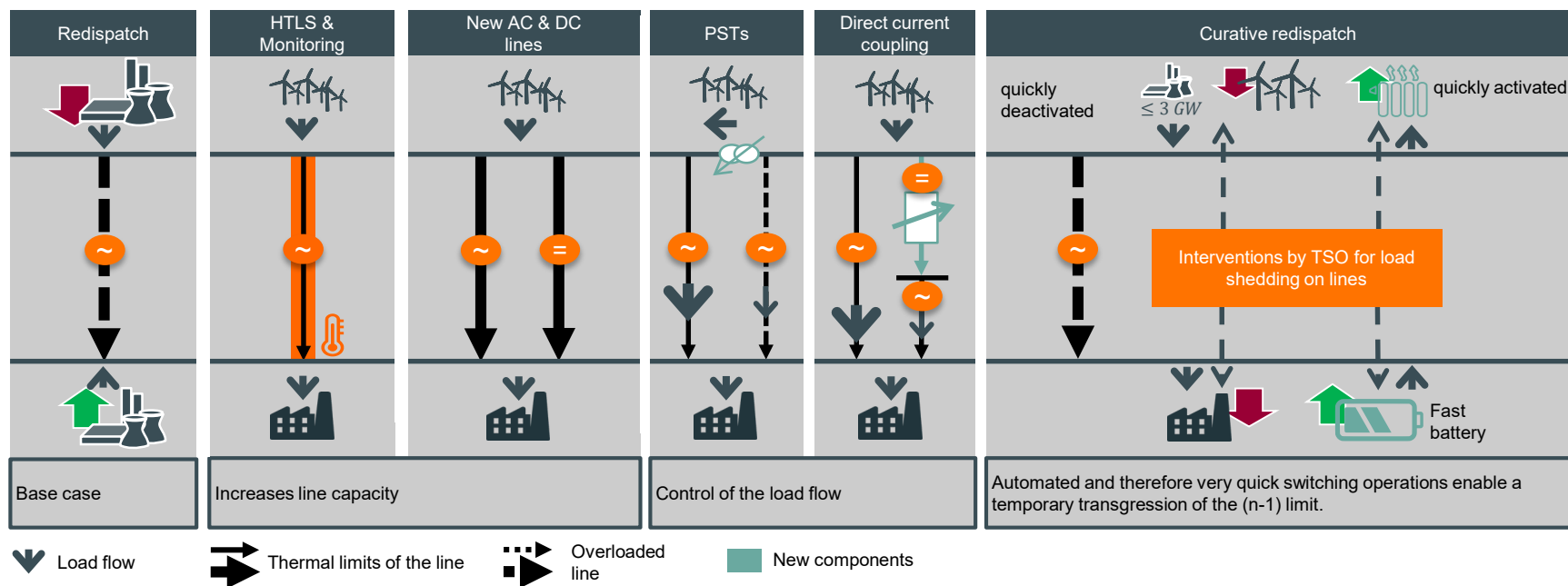

Tool-box of measures as well as increasing level of digitization and automation required to keep high level of security of supply.

High system security despite of additional RES generation capacity

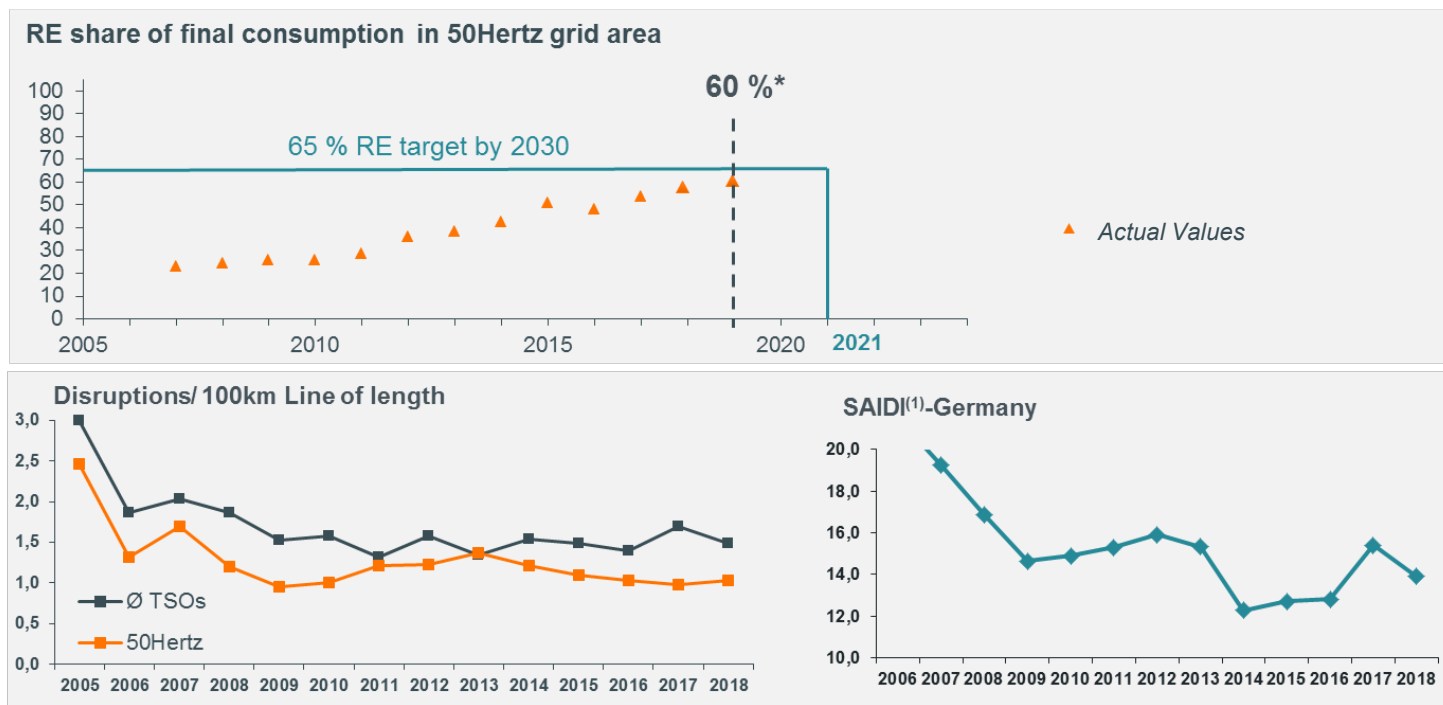

Source: 50Hertz, *preliminary data; as of 08/01/2019

System Average Interruption Duration Index in minutes
Source: Bundesnetzagentur (BNetzA)

Thank You!

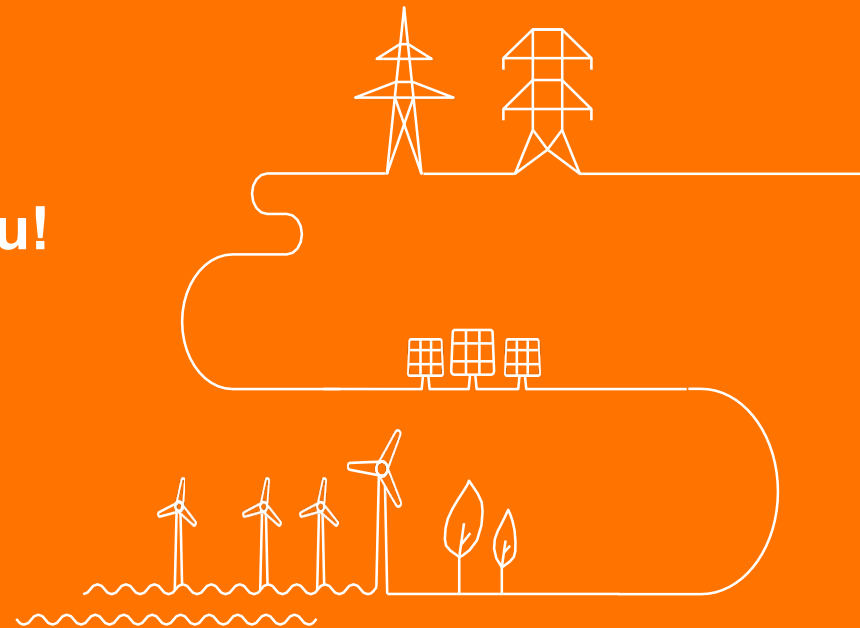



PANEL TWO:

Curtailment Risk

Moderator:

- Dr. Kira Lawrence
Eagleton Science Fellow, NJ BPU

Panelists:

- Timothy Frost
Vice President, Electric Transmission, Con Edison
- Michael Kormos
Senior Vice President, Transmission and Compliance, Exelon
- Howard Kosel
Partner, Anbaric
- Lorenz Mueller
Head of Regulatory Affairs, 50Hertz Transmission GmbH



PANEL THREE:

Post-Commercial Operational Risk

Moderator:

- Andrea Hart
Counsel's Office, NJ BPU

Panelists:

- James Cotter
Vice President, Wind Development, Shell New
Energies US
- Elisabeth Treseder
New England Market Lead, Equinor Wind US
- Øyvind Vessia
Head of Regulatory Affairs, Ørsted

Panel Three

Post-commercial operational risk

Øyvind Vessia, Senior Manager, Regulatory Affairs Market Development

Compensation

- Compensation during repair (planned and unplanned)
- Rules for validation of lost production
- Rules for consequential damage (imbalance, increased maintenance)
- Incentives for correct level of maintenance
- Liability



Lifetime extension
Transmission



Divestments of grid connection after commissioning

Points to consider if third party take-over:

- What is the value of the grid asset?
- What costs are covered?
- Innovation "allowed"? Or too risky for the developer?

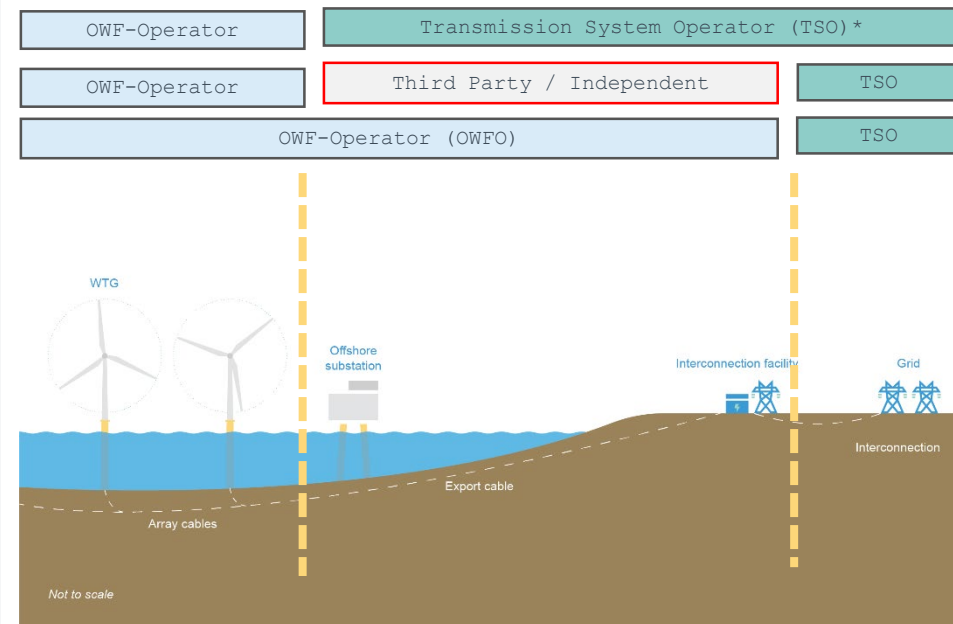

Thank you



PANEL THREE:

Post-Commercial Operational Risk

Moderator:

- Andrea Hart
Counsel's Office, NJ BPU

Panelists:

- James Cotter
Vice President, Wind Development, Shell New
Energies US
- Elisabeth Treseder
New England Market Lead, Equinor Wind US
- Øyvind Vessia
Head of Regulatory Affairs, Ørsted



Written Comments

- The Board will be accepting written comments on this matter until 5pm E.S.T. on March 12, 2021.
- Please submit your electronic comments in PDF or Word format to board.secretary@bpu.nj.gov or see meeting notice for instructions for e-filing and written comments.
- Please reference Docket No. QO20100630 in the subject line of your comments.

THANK YOU!



Follow NJBPU
on social media:

